

IN-TA-CT[®]

Dynamicfilter

The Taprogge logo consists of a red stylized 'G' symbol followed by the word 'Taprogge' in a blue, sans-serif font.

Filtration

3

Innovative Automatic Backwash Filter for the Fine Filtration of Liquids

The Dynamicfilter is exemplary for the fact that even in such a well researched field as fine filtration there is still room for innovations. The idea is quite simple: by the combination of two well-known principles, namely the "dynamic backwash" and "active filter elements", the TAPROGGE R&D has succeeded in the development of an amazingly simple and extremely effective filtration solution - with impressive results in terms of price-performance ratio. Filter cleaning is effected automatically, without interruption of flow. The filter has been extended to a complete series and covers the filtration needs for fineness degrees of 50 µm up to 5 mm with volume flows from 18 to 4,000 m³/h.

Field of Application:

- Protection of objects installed downstream, as pre-filtration or final filtration stage, resp., in seawater, brackish water, river water, well water, cooling water, cooling tower make-up water, fire extinguishing water, spray water, service water, drinking water, process water, waste water, emulsions, product liquids
- Special application: filtration of mussel larvae
- Application as partial flow filter

Dynamicfilter in industry

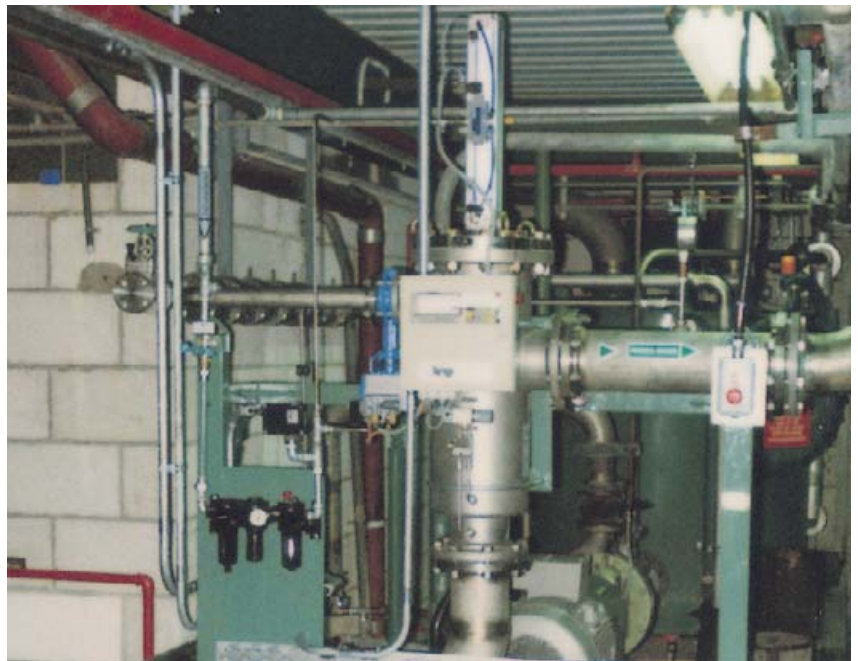

Filter Design

According to the required filter fineness and type of fouling to be expected, the Dynamicfilter can be equipped with "active filter elements" (1), wedge wire, or perforated steel sheet. The determination of its type is governed by the relevant application.

Opposite to the inlet opening (2) a flushing disc (3) is arranged that, during backwash, is axially moved in the filter element by means of a pneumatic cylinder (4). During this process a gap is created between the filter element and the flushing disc.

Opposite to the outlet opening (5) that is arranged radially at the filter housing, there is the connection for the debris discharge valve (6).

A differential pressure monitor (7) controls the adjustable backwash point and starts the backwash process. Additionally the backwash process can be initiated by a timer.

The control panel (8) is fixed to the filter housing and connected with the switching and signalling devices of the filter.

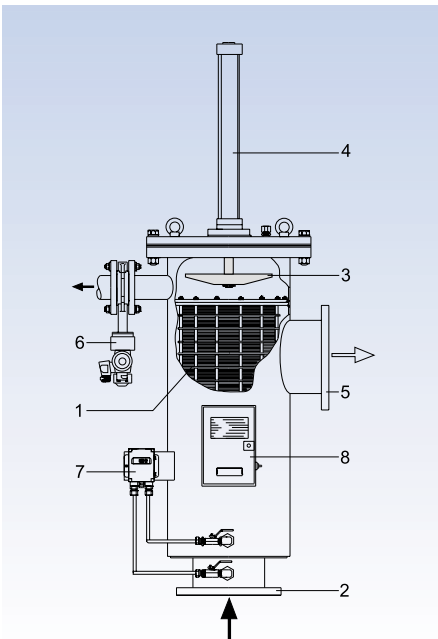

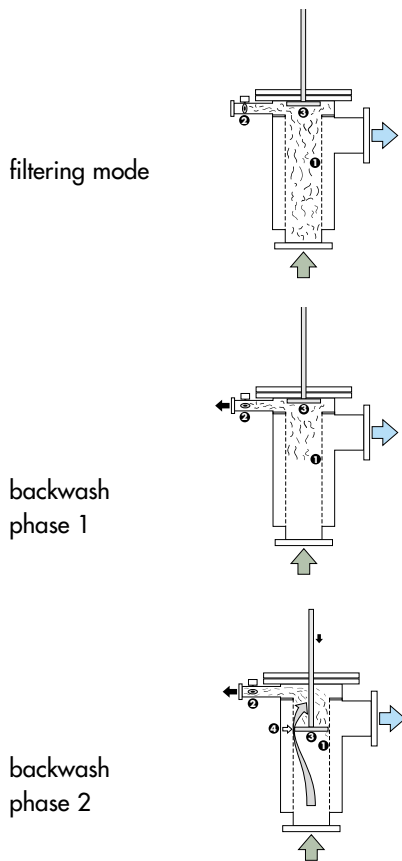

Filter Function

1. Filter Operation

The debris discharge valve (2) is closed. The flushing disc (3) is in basic position outside of the filter element. The medium to be filtered flows through the filter element from inside to outside. As a result, the fouling particles accumulate on the inside of the filter element (1). The differential pressure measuring system recognizes the increase of accumulating particles and, once a pre-set backwash point has been reached, initiates the backwash process in two phases:

2. Backwash Phase 1:

The debris discharge valve opens and releases the discharge flow whose driving force results from the pressure drop in the discharge pipe. This measure initially causes only the easily detachable coarse particles to be lifted off from the filter surface and discharged via the discharge pipe.

3. Backwash Phase 2:

In this phase the difficult particles are cleaned off. For this purpose the pneumatic cylinder moves the flushing disc (3) into the filter element (1). At the relevant position of the flushing disc (4) the "principle of dynamic backwash" is now locally prevalent, freeing the filter gaps most effectively from the debris particles by reverse flow. Subsequently the flushing disc moves back to basic position, and the debris discharge valve closes.

Principle 1: Dynamic Backwash

This principle is the basic design feature of the Dynamicfilter. The backwash mechanism is due to the partial increase of the flow velocity in the gap between flushing disc and filter surface, whereby the static pressure is dramatically reduced in this place, thus initiating a flow reversal in the openings of the filter element. The continuous throughflow is at any time safeguarded during the backwash process because the flushing disc travels only over about two thirds of the length of the filter element.

The cleaning of the filter surface that is not covered by the flushing disc is now very easy. It is done without further action, directly and compulsorily, according to the principle of dynamic backwash; for after the cleaning of the area covered by the flushing disc the static pressure in the uncovered area is reduced as a result of the increased flow velocity and thus releases the backwash effect described above. Finally the filter has been completely cleaned by backwash.

Principle 2: Active Filter Elements

In contrast to filtering techniques known to date, the patented TAPROGGE filter cartridges consist of "active filter elements" with filter gaps that open during backwash. In the filtration process these "active filter elements" fix the filter gaps to a defined measure.

By the flow reversal generated by the flushing disc the filter gaps open, so that even jammed particles can be released and cleaned off.

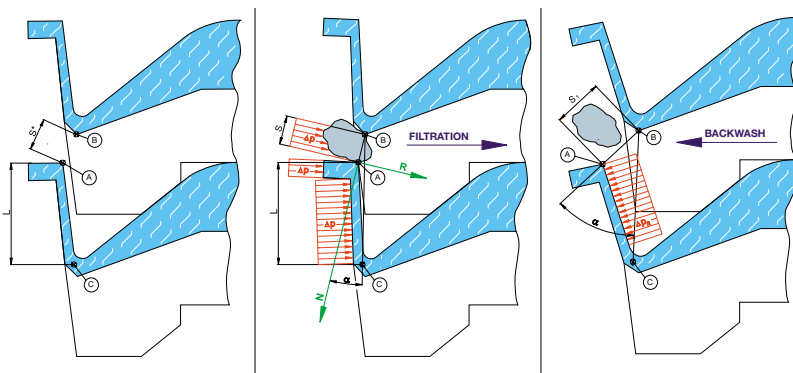

Technical Data

series:	Dynamicfilter
volume flow:	18 – 4,000 m ³ /h
connecting diameters:	DN 80 - DN 600
type:	TD
filter fineness degrees:	50 - 5,000 µm
filter element:	"active filter elements" made of plastic (50 - 500 µm), wedge wire, perforated steel sheet
material of housing:	steel, rubberlined; stainless steel; PVC
temperature:	max. 80 °C
control:	programmable controller
actuation:	pneumatic
special executions:	on request

Installation variants Dynamicfilter

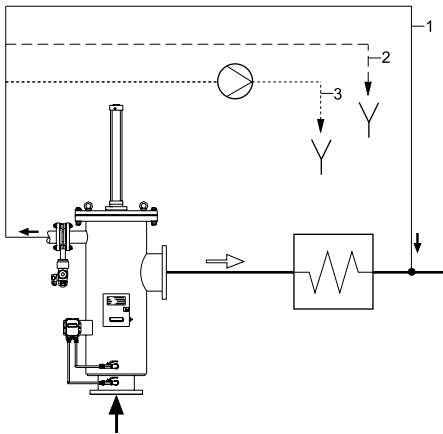

Installation

The Dynamicfilter is normally arranged directly upstream of an object to be protected, such as a heat exchanger or an additional stage of filtration, or is installed as partial flow filter. The backwash process necessitates a pressure drop in the discharge pipe. If the pressure drop is generated by the object to be protected itself, the flow can be re-injected downstream of the object (1).

The backwash water can also be discharged atmospherically by making use of the static overpressure downstream of the filter (2), or can be transported via a booster pump (3).

Technical Features and Benefits

Functional Safety

- Fulfils the requirements of the European Pressure Equipment Directive 97/23/EC
- Enhanced functional safety by the use of "active filter elements". As they require clearly lower backwash velocities than conventional filter elements, the "active filter elements" render filtration feasible after all, even in cases where the conventional filter elements would be permanently blocked.

Economy made by TAPROGGE

- Permanent availability of the plant by automatic, uninterrupted filter operation
- Avoidance of scheduled or unscheduled outages for cost-intensive manual cleaning procedures
- Low installation costs by flexible installation - vertical or horizontal - directly in the piping
- Supply as plug & work standard: all components are completely prefitted in the TAPROGGE works. Additional final assembly on site is not necessary
- Savings in operational costs by filter operation according to the principle of dynamic backwash. The filter thus operates with low pressure loss and low backwash pressure - this is rewarding especially in those cases where only low system pressures are available
- Low maintenance cost by filter design incorporating little wear and tear
- Excellent accessibility of all internal parts without dismantling of the filter

TAPROGGE Care & Comfort Package

Quality right from the Start

- Performance by TAPROGGE as per DIN EN ISO 9001
- Safety of design by fulfilling the requirements of the European Pressure Equipment Directive 97/23/EC
- Application of a management system for safety, health and environmental protection (SCC)
- Standard documentation; documentation upon customer's request, respectively
- The use of extremely corrosion-resistant materials with long lifetimes safeguards the preservation of the value of investment.

Compatibility by IN-TA-CT® Modules

- The Dynamicfilter is a modular element of IN-TA-CT®, our integral principle for the optimization of cooling water circuits.
- By combination with our TAPIS® prescreening system upstream and a TAPROGGE tube cleaning system of type CCS or E1 downstream, an overall solution presents itself for the protection of heat exchangers or condensers from coarse debris, micro and macro fouling. Without interfaces - and inclusive of the TAPROGGE System Guarantee.

Competence and Experience out of one Hand

- Application consultancy, project management, fabrication, installation and commissioning of the Dynamicfilter are available from TAPROGGE out of one hand.
- With more than 12,000 successful applications, TAPROGGE can make use of its application-technological experience in its special field that stands unparalleled the world over. This plus of competence is indispensable for difficult media and unknown cleaning behaviour.
- In addition to that, the cooling water test circuits of TAPROGGE's Technological Centre allow a particularly reliable and cost-efficient simulation of site conditions.

Comprehensive Operator Support by IN-TA-S®

- By the installation and commissioning of the Dynamicfilter, operators have immediate access to IN-TA-S®.
- By IN-TA-S®, TAPROGGE takes care of the operator in all questions of operation and maintenance. Scope, duration and frequency of the care can be determined by the operator.



Postal address:

TAPROGGE Gesellschaft mbH
58292 Wetter
Germany

Company address:

TAPROGGE Gesellschaft mbH
Schliemannstraße 2-14
58300 Wetter
Germany

Tel.: +49 (0)2335 / 762-0

Fax: +49 (0)2335 / 762-245

E-Mail: info@taprogge.de

Homepage: <http://www.taprogge.de>

© TAPROGGE Gesellschaft mbH. All rights reserved.
TAPROGGE®, IN-TA-CT®, IN-TA-S® and TAPIS® are
registered trademarks of TAPROGGE Gesellschaft mbH.