

**GESTRA**

***Steam Traps and Steam Trap Testing***

*For all applications*

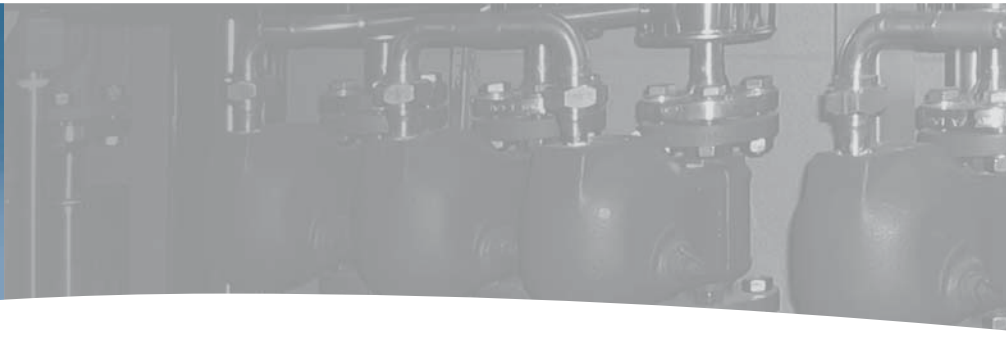



## The GESTRA Steam Trap Range

### What are steam traps?

To be able to operate a plant over a long period with an optimum efficiency the choice of the correct valves is of vital importance.

Amongst these valves are steam traps which have an important role to play. Steam must be trapped within heating equipment until it has surrendered all heat energy, at which point the condensate thereby formed must be immediately discharged. The optimum efficiency of a steamheated plant is dependent upon the performance of steam traps.

One type of steam trap cannot be equally well suited for the various applications and requirements, therefore GESTRA offers a comprehensive steam trap range developed and refined on practical applications over the years. The choice of the steam trap type depends, of course, on the plant

condition. We are willingly prepared to assist you in selecting the most economic solution for your particular application.

### What are the advantages of GESTRA steam traps?

- ▶ Easy maintenance – our traps can be checked, cleaned and repaired without being removed from the pipework
- ▶ Interchangeable – our various trap types have standardized face-to-face dimensions, sizes and end connections and are therefore interchangeable without any modification to the pipe layout.
- ▶ Tight shut-off, without loss of live steam.
- ▶ Automatic air-venting.
- ▶ Unaffected by dirt.
- ▶ Production tested – besides the legally required tests (e.g. hydraulic test) our trap regulators are tested under operating conditions (steam, condensate).
- ▶ Complies with recognized standards – our traps meet the relevant DIN standards and regulations and are in accordance with the AD bulletins (AD – Arbeitsgemeinschaft Druckbehälter = German pressure vessel regulations authority) with regard to choice of material, pressure and temperature ratings. On request test certificates to EN 10204.

### The three different steam trap types



**BK**  
The BK is a thermostatic steam trap with Duo stainless (bimetallic) regulator. Advantage: particularly robust.



**MK**  
The MK is a thermostatic steam trap with membrane regulator. Advantage: very sensitive response characteristic.



**UNA**  
The UNA is a float trap. Advantage: condensate discharge at extreme and sudden condensate flowrate and pressure fluctuations.

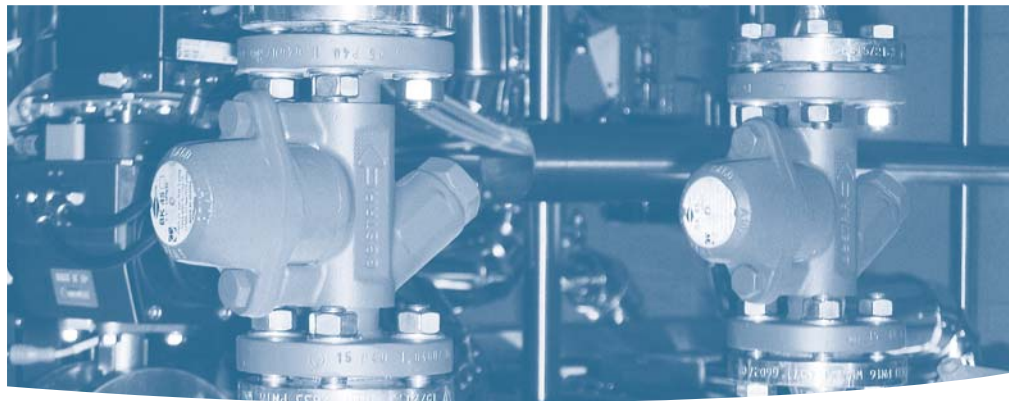
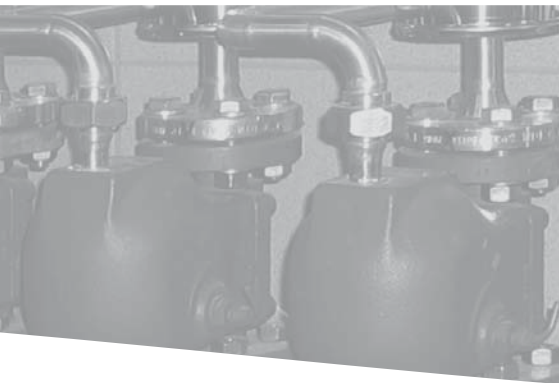

## Short Guide to Steam Trap Selection

Not all steam trap types are equally suitable for a given application. Depending on the operating conditions and service in question, one or more systems will be particularly well suited.

The following table contains 15 criteria for steam trap selection based on the operation of the plant and the specific requirements on the part of the plant owner.

### Criteria

Criteria		Steam trap types				Ratings: 1 = Excellent 2 = Good 3 = Fair or conditional – = Not recommended, unsuitable
		Trap type BK with bimetallic regulator	Trap type MK with membrane regulator	Ball float trap type UNA with Duplex control	Ball float trap type UNA with Simplex control	
1. Operation with different condensates	Condensate from steam	1	1	1	1	For "cold" condensates or condensates with a saturation curve deviating from that of water only float traps featuring Simplex control (without thermal venting) can be used.
	Condensate from compressed air	–	–	–	1	
	Condensate, distillate from chemical products	–	–	–	1	
2. Different modes of operation	Continuous operation: Constant formation of condensate; flowrate and pressure vary	2	1	1	1	* e.g. air venting difficulties * Air venting difficulties ** With partial load (reduced differential pressure) flowrate possibly not sufficient
	Discontinuous operation: Intermittent formation of condensate; flowrate and pressure vary strongly	2	1	1	3*	
	Any operation: Heat exchanger may be controlled on the steam side	3**	2	1	3*	
3. Operation with back pressure	Up to approx. 30% of upstream pressure	1	1	1	1	* Adjustment may be necessary * Adjustment may be necessary
	From 30 % to 60 % of upstream pressure	3*	1	1	1	
	More than 60 % of upstream pressure	3*	1	1	1	
4. Sensitivity to dirt	Highly contaminated condensate	1	1	1	1	
5. Air-venting	Automatic	1	1	1	3*	* Manual air-venting
6. Condensate discharge at definite temperatures	Condensate temperature nearly boiling temperature	2*	2**	1	1	This may apply to small heat exchangers (e.g. laboratory equipment) * Adjustment may be necessary ** Might require special membrane regulator
	Condensate undercooling approx. 30 K (required)	1*	1**	–	–	* with U-type regulator or through adjustment ** with U-type capsule
	Condensate undercooling adjustable	2*	–	–	–	* Adjustment causes a reduction in flowrate! If possible, use steam trap with UBK
7. Frost resistance		1	1	1*	3*	* Only ensured with V-type design
8. Condensate discharge without loss of live steam	Intermittent condensate formation	1	1	1	1	
	Reduced condensate formation (< 10 kg/h)	1	1	1	1	
	Continuous condensate formation (> 10 kg/h)	1	1	1	1	
9. Resistance to waterhammer		1	1*	3*	3*	* Built-in non-return valve = 1
10. Non-return valve action		1	1*	–*	–*	* Built-in non-return valve = 1
11. Application in vacuum		3	2	1	1	
12. Installation in any position		1	1	–*	–*	* UNA 1.. is convertible
13. Easy of maintenance		1	1	1	1	
14. Service life of control unit		1	2	1	1	
15. Use with superheated steam		1	3	3*	1	* UNA 1.. as for MK, UNA 2.. not recommended

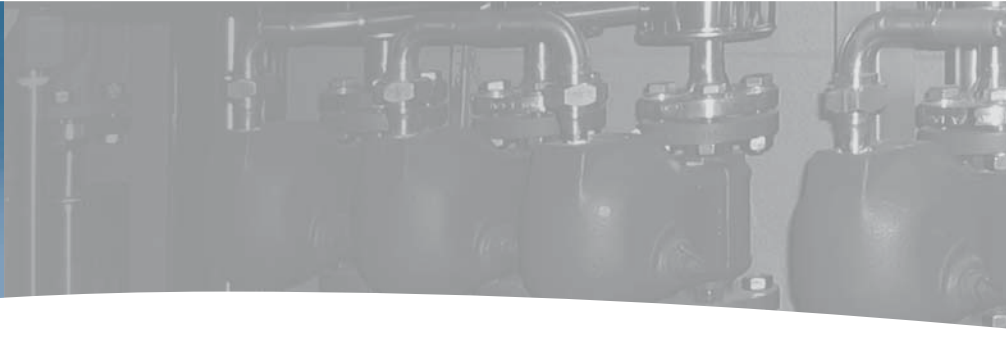

## Duo Steam Traps BK

Thermostatic steam traps with Duo stainless steel (bimetallic) regulator  
Pressure ratings up to PN 630.

For roughest operating conditions. Unexcelled service life.

Operating principle resulting in a sturdy design unaffected by waterhammer and frost.

May also be used as air vents.

### Operation

Opening and closing are controlled by the temperature sensor of Duo stainless steel plates and the stage nozzle operating together. During start-up of the plant and in the presence of cold condensate and air the Duo stainless steel plates are flat. The service pressure acts in the opening direction, the valve is completely open.

With rising condensate temperature the plates deflect and draw the stage nozzle towards the closed position (a thermostatic process). The service pressure and the pressure built up in the stage-nozzle chamber by flashing produce an opposite force (a thermodynamic process). The orifice area is determined by the prevailing state of equilibrium between the temperature-dependent closing force and the pressure-related opening force.

Immediately below saturation temperature (boiling temperature) the plates are deflected to such an extent that the stage nozzle is almost closed. As a consequence the pressure in the stage-nozzle chamber decreases and breaks down as the flashing across the stage nozzle then closes. The deflection of the Duo stainless steel plates created by the temperature is not sufficient to produce, over the complete pressure range, the force required to counteract the force acting on the stage nozzle in the opening direction. The plates are therefore arranged in a stack which acts as a spring having a characteristic that adapts itself to the force acting on the stage nozzle varying with the service pressure. Thermostatic and spring characteristics are balanced so that the opening and closing temperatures are always just a few degrees below saturation temperature.

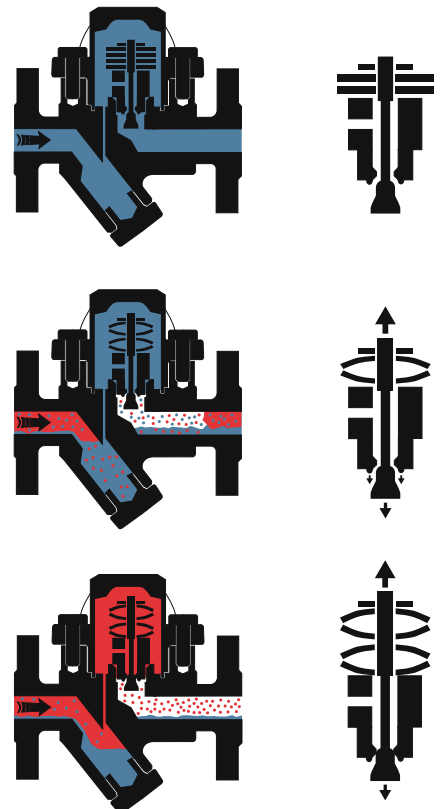

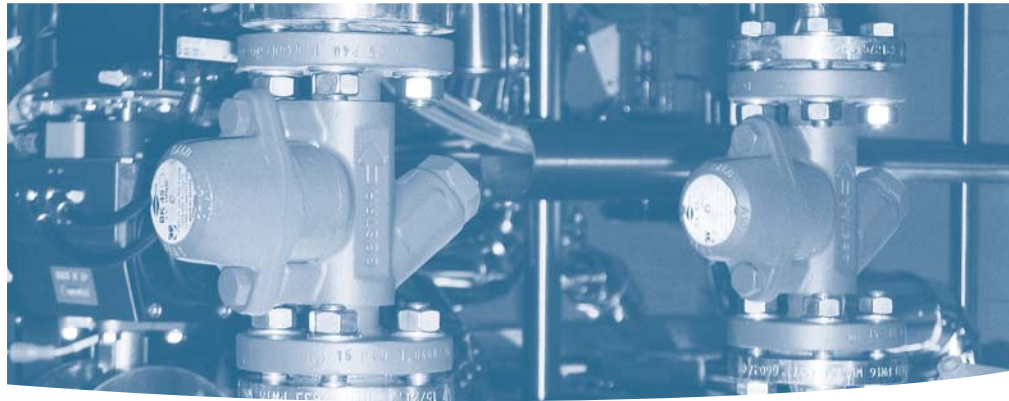
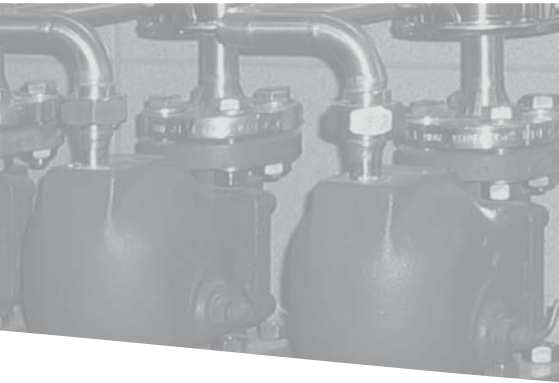

**Rhombus-shaped cover** ▶

secured with only two bolts, which are easy to insert and easy to use in restricted spaces

**Temperature feeler of Duo stainless steel plates** ▶

Thermostatic control.  
Corrosion-resistant throughout, fatigue-free, not subject to ageing

**Thermovit regulator** ▶

Light and compact regulator unit, replaceable without removing body from pipeline.  
Withstands waterhammer and freezing.  
Easy maintenance

**Stage nozzle** ▶

Thermodynamic control. Wear resistant.  
Freely mounted for non-return valve action

**Large-surface strainer** ▶

**Recessed flat gasket for superior sealing**

**Metal base bushing**

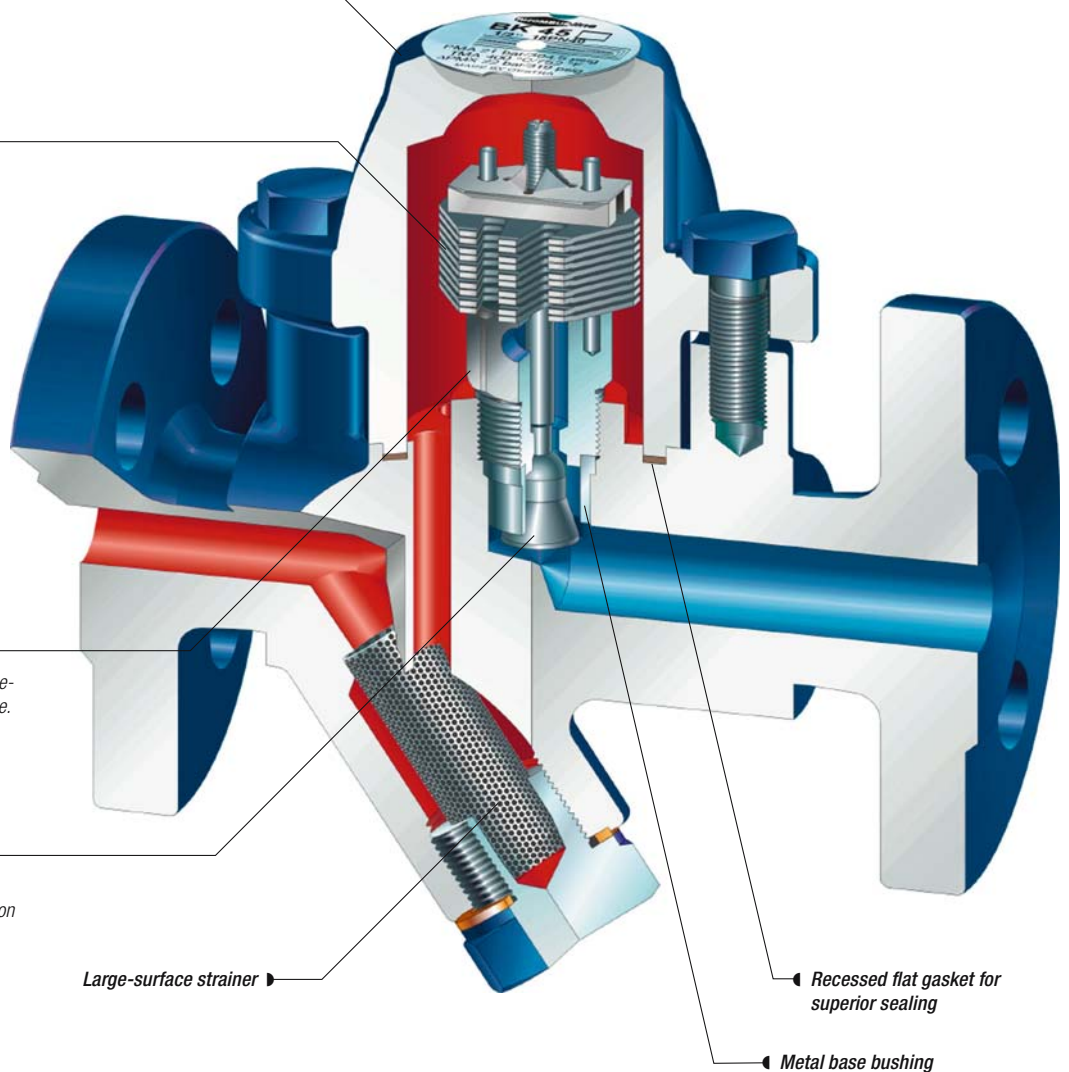

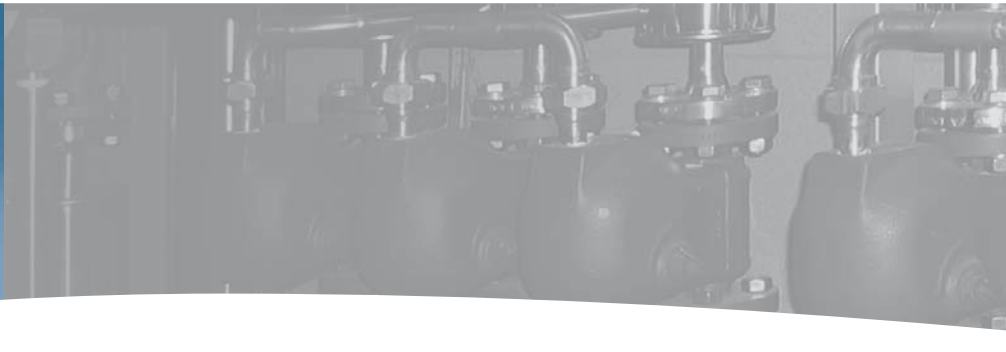

## BK Types and Connections

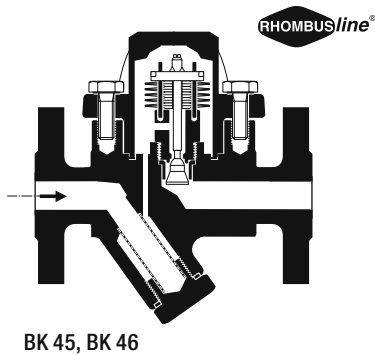

BK 45, BK 46

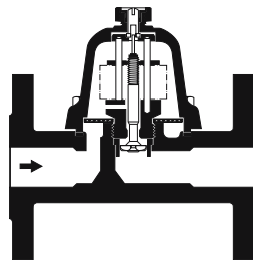

BK 15

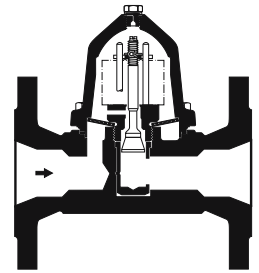

BK 27 N

### The BK traps at a glance

Type	Material	Max. differential pressure bar (psi)	Connections, DN			
			Flanged	Screwed	Socket-weld	Butt-weld
BK 45	1.0460	22 (320)	15–25 mm (1/2"–1")	1/2"–1"	1/2"–1"	15–25 mm (1/2"–1")
BK 15	1.0460	22 (320)	40–50 mm (1 1/2"–2")	1 1/2"–2"	1 1/2"–2"	40–50 mm (1 1/2"–2")
BK 46	1.5415	32 (465)	15–25 mm (1/2"–1")		1/2"–1"	15–25 mm (1/2"–1")
BK 37	1.5415	45 (650)	15–25 mm (1/2"–1")		1/2"–1"	15–25 mm (1/2"–1")
BK 27 N	1.5415	45 (650)	40–50 mm (1 1/2"–2")		1 1/2"–2"	40–50 mm (1 1/2"–2")
BK 28	1.5415	85 (1230)	15–25 mm (1/2"–1")		1/2"–1"	15–25 mm (1/2"–1")
BK 29	1.7335	110 (1600)	15–25 mm (1/2"–1")		1/2"–1"	15–25 mm (1/2"–1")
BK 212-F91	1.7383/1.4903	250 (3625)	15–25 mm (1/2"–1")		1/2"–1"	15–25 mm (1/2"–1")
BK 37-ASME	A182-F-12	45 (650)	15–25 mm (1/2"–1")		1/2"–1"	15–25 mm (1/2"–1")
BK 28-ASME	A182-F-12	85 (1230)	15–25 mm (1/2"–1")		1/2"–1"	15–25 mm (1/2"–1")
BK 29-ASME	A182-F-12	110 (1600)	15–25 mm (1/2"–1")		1/2"–1"	15–25 mm (1/2"–1")
BK 212-ASME	A182-F-22	250 (3625)	15–25 mm (1/2"–1")		1/2"–1"	15–25 mm (1/2"–1")

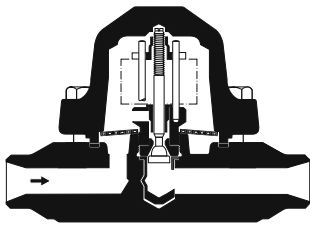
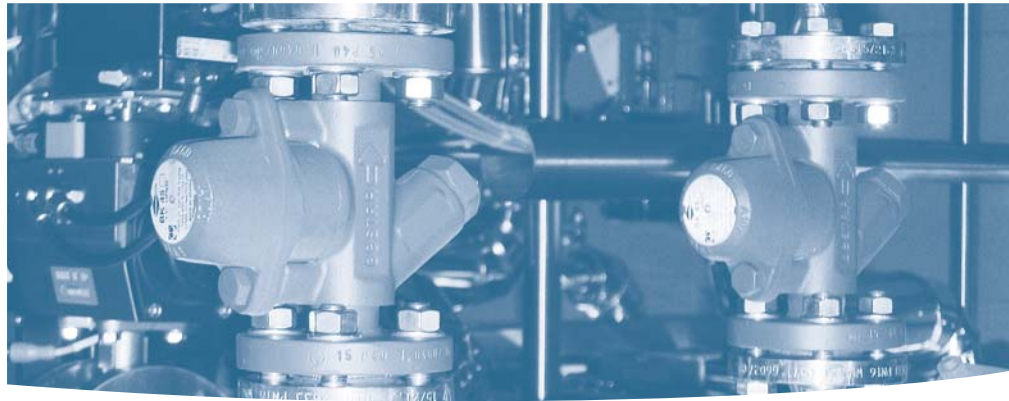
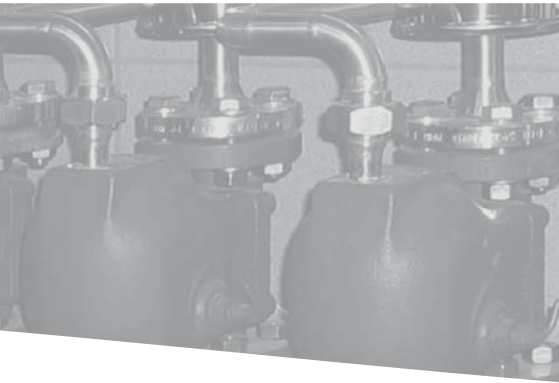

BK 37, BK 28, BK 29

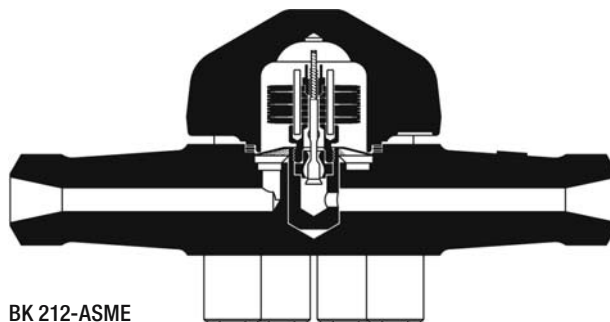

BK 212-ASME

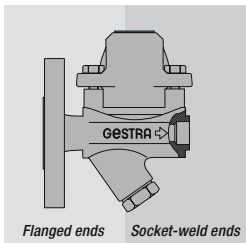

Flanged ends Socket-weld ends

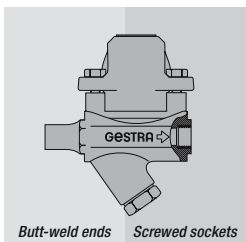

Butt-weld ends Screwed sockets

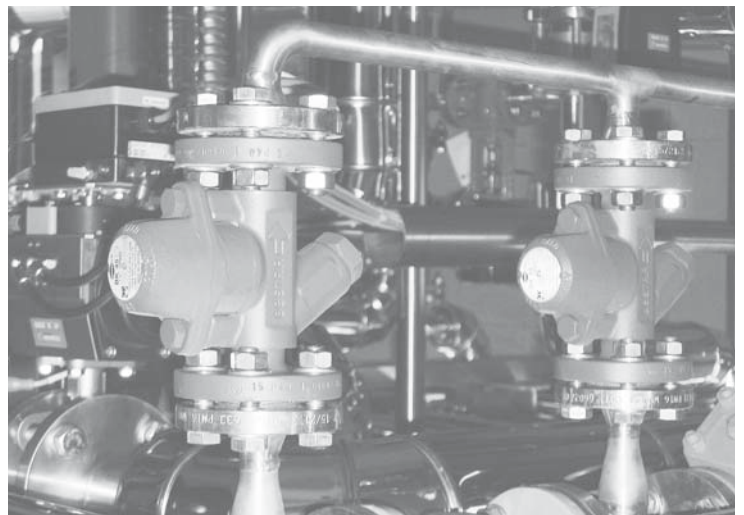

Steam trap BK 45

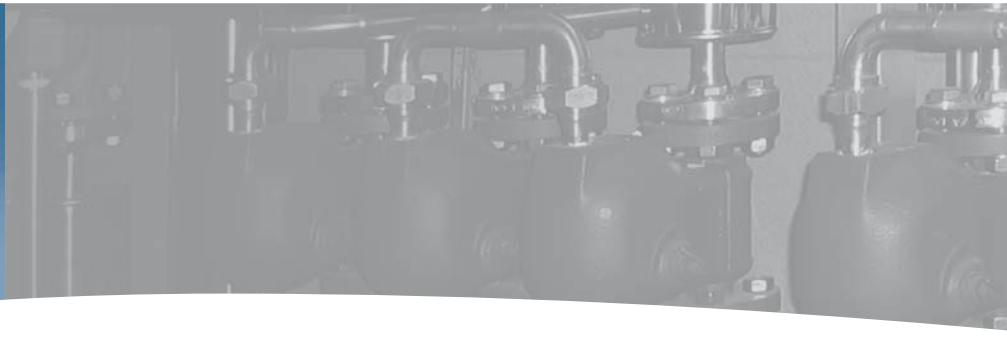

## Steam Traps MK

**Thermostatic steam traps with membrane regulator. Pressure ratings up to PN 40. Unexcelled regulating accuracy due to thermostatic capsule.**

**May also be used for thermal air-venting.**

**With Tandem seat (double sealing) for low condensate flowrates. For larger condensate flowrates with single seat.**

The main feature of the MK traps is an unusually sensitive response. They are particularly suited for the drainage of such heat exchangers that would appreciably be affected in their operation by even the slightest banking-up of condensate. The operation of the trap is neither influenced by its position of installation nor by upstream or back pressure. The thermostatic capsule and all other internals are made of corrosion-resistant materials. The membrane of Hastelloy® is completely corrosion-resistant even with acid condensate and condensate containing chlorides.

Two different designs of the thermostatic capsule are available:

standard capsule "N" for instantaneous condensate discharge without any banking-up. Opening temperature approximately 10 K (degC) below saturation temperature.

undercooling capsule "U" for additional energy savings (utilization of a certain amount of sensible heat by banking-up of condensate, decreasing the amount of flash steam). Opening temperature approximately 30 K (degC) below saturation temperature. The integral non-return valve with hollow cone and reduced mass protects the cap-

sule from waterhammer. The asbestos-free cover gasket is maintenance-free. The large-surface strainer protects the trap from dirt ensuring longer maintenance intervals. For particularly aggressive condensate and special hygienic requirements the MK 45 A is available made completely of stainless steel.

### Operation Membrane regulator

#### Opening:

The capsule of the membrane regulator is filled with a liquid having an evaporation temperature which is just a few degrees below the saturation temperature of water. During shut-down or start-up of the plant, i.e. if cold condensate is present, the liquid filling is completely condensed. The pressure in the capsule is lower than the surrounding pressure (service pressure); the membrane with the valve disc is pushed in the opening direction.

#### Closing:

With rising condensate temperature, the liquid filling starts to evaporate. The pressure in the capsule rises; the membrane with the valve disc is moved in the closing direction. Just before the condensate has reached its saturation temperature, the trap is closed completely.

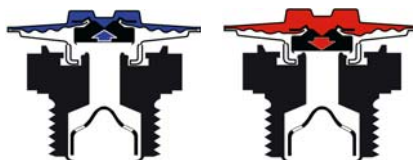

### Tandem seat

The self-centering valve cone ① ensures steam-tight closure. With rising temperatures the additional flat seat ② closes too and provides a further guarantee of tightness, even in the presence of dirt particles. Moreover the pressure drop across the orifice area of the trap in two stages reduces wear and enhances the life of the trap.

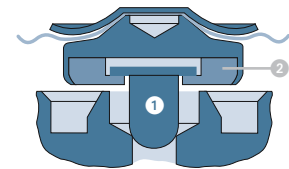

#### During plant operation

*Seat 1 closes (regulator is pushed in the closed position)*

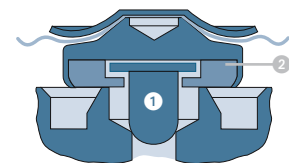

#### Trap closed

*Both seats are tightly shut off*

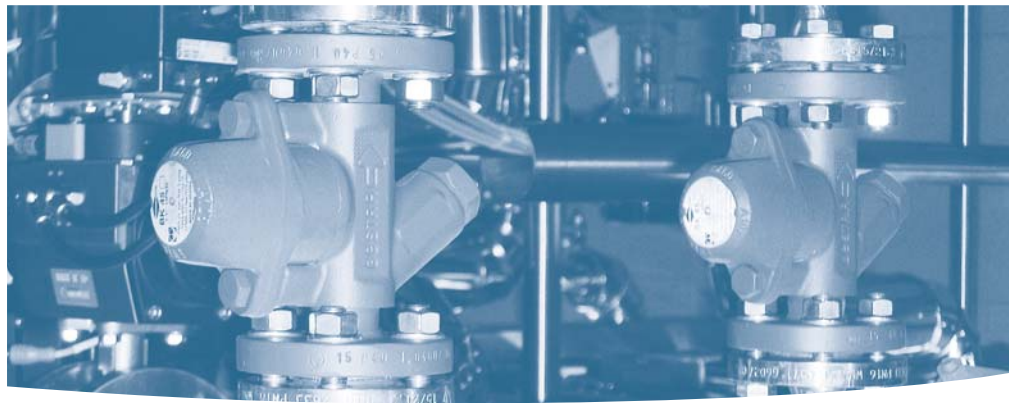
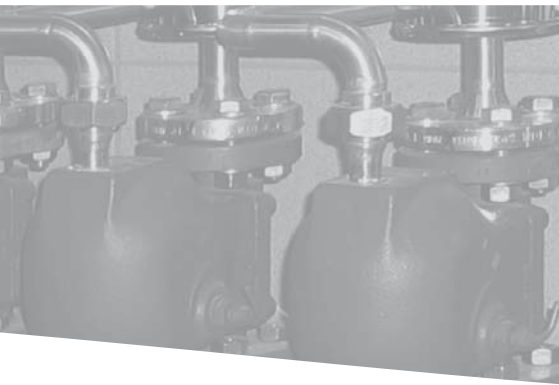

**Rhombus-shaped cover** ▶

secured with only two bolts, which are easy to insert and easy to use in restricted spaces

**Thermostatic capsule** ▶

Regulator unit replaceable without removing body from pipeline. Precise reaction to any change in temperature. Corrugated membrane of Hastelloy®. High elasticity, long service life

**Tandem seat** ▶

Double sealing

**Non-return valve with hollow cone and reduced mass** ▶

Quick closing in the event of waterhammer

**Large-surface strainer** ▶

**Recessed flat gasket for superior sealing**

**Metal base bushing**

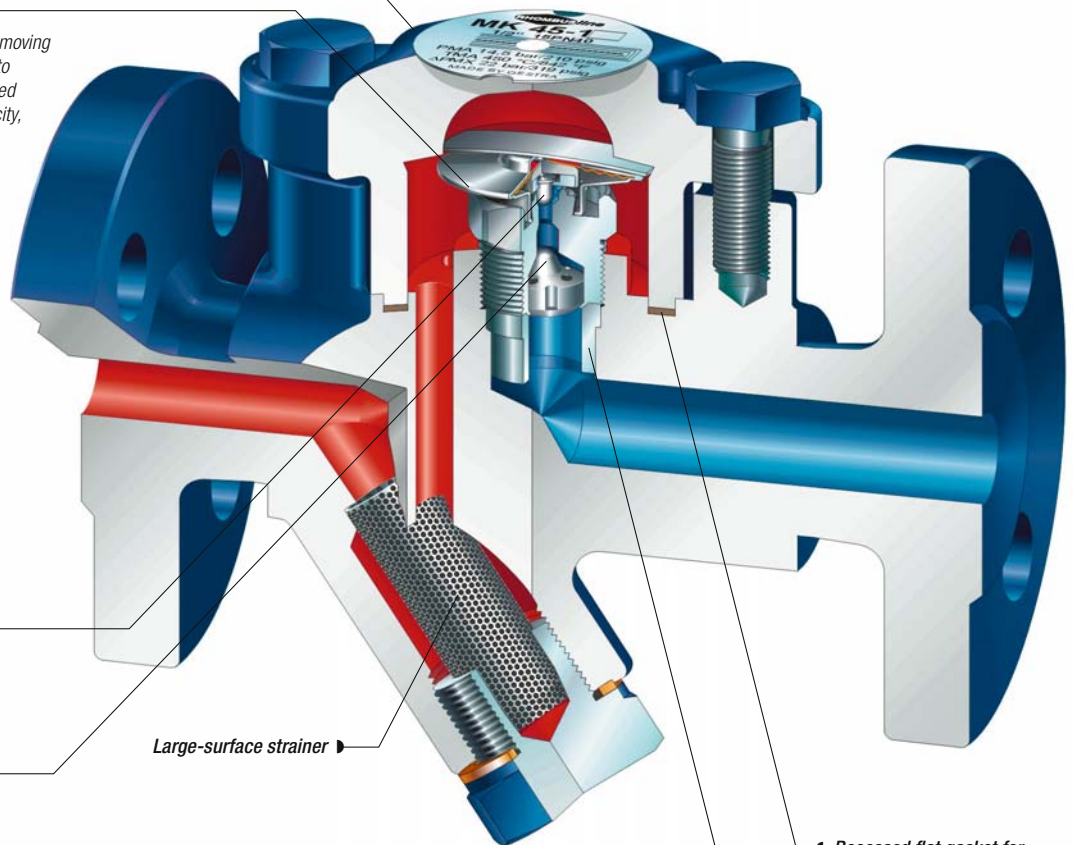

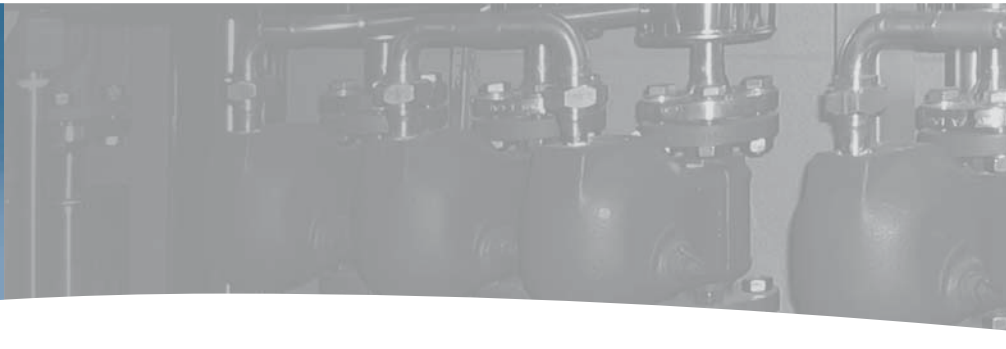

## MK Types and Connections

MK 45  
 MK 45 A  
 MK 35/2S (DN 25)  
 MK 35/2S3 (DN 25)  
 MK 25/2 (DN 40/50)  
 MK 25/2S (DN 40/50)

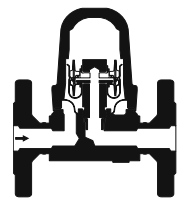

MK 35/2S DN 25

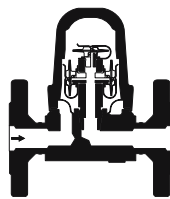

MK 35/2 S3 DN 25

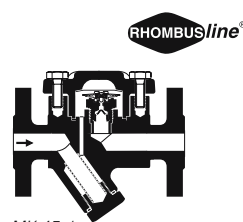

MK 45-1  
 MK 45 A-1

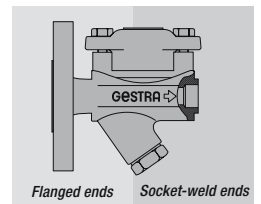

Flanged ends    Socket-weld ends

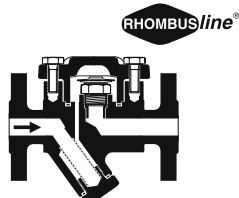

MK 45-2  
 MK 45 A-2

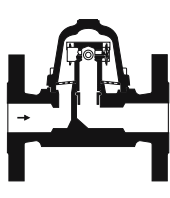

MK 25/2 DN 40/50

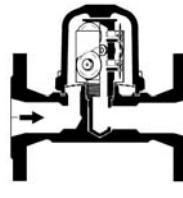

MK 25/2S DN 40/50

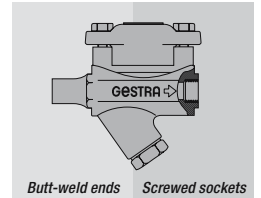

Butt-weld ends    Screwed sockets

### The GESTRA MK steam traps at a glance

Type	Material	Max. differential pressure bar (psi)	Connections, DN			
			Flanged	Screwed	Socket-weld	Butt-weld
MK 45-1	1.0460	22 (320)	15–25 mm (1/2"–1")	1/2"–1"	1/2"–1"	15–25 mm (1/2"–1")
MK 45-2	1.0460	22 (320)	15–25 mm (1/2"–1")	1/2"–1"	1/2"–1"	15–25 mm (1/2"–1")
MK 35/2S 2 capsules	1.0460	22 (320)	25 mm (1")	1"	1"	25 mm (1")
MK 35/2S3 3 capsules	1.0460	22 (320)	25 mm (1")	1"	1"	25 mm (1")
MK 25/2 4 capsules	1.0460	22 (320)	40, 50 mm (1 1/2", 2")	1 1/2"–2"	1 1/2"–2"	
MK 25/2S 9 capsules	1.0460	22 (320)	40, 50 mm (1 1/2", 2")	1 1/2"–2"	1 1/2"–2"	
MK 45 A-1	1.4404	22 (320)	15–25 mm (1/2"–1")	1/2"–1"	1/2"–1"	15–25 mm (1/2"–1")
MK 45 A-2	1.4404	22 (320)	15–25 mm (1/2"–1")	1/2"–1"	1/2"–1"	15–25 mm (1/2"–1")

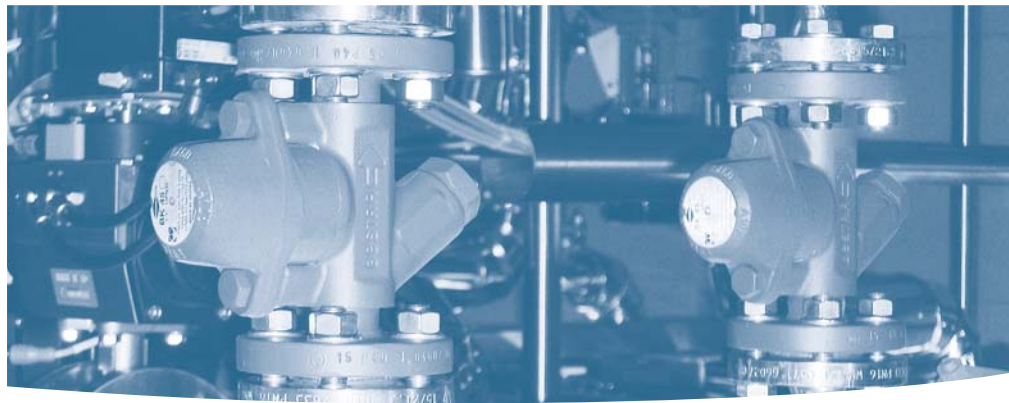
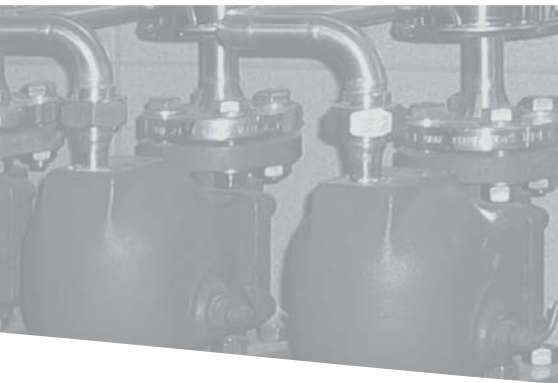

## GESTRA Duo Super steam traps TK for very large condensate flowrates up to PN 25

The traps with thermostatic pilot control using thermostatic capsules are used for the discharge of very large amounts of condensate. The regulating characteristic and the control effect of these traps are similar to those of the membrane traps. If, for a special application, the trap must not close

completely, a leak passage can be adjusted. It is, however, also possible to restrict the valve lift to obtain continuous operation. To guarantee a rapid response of the traps they are adjusted at the factory so that a leak passage of approx. 1–2% is obtained.

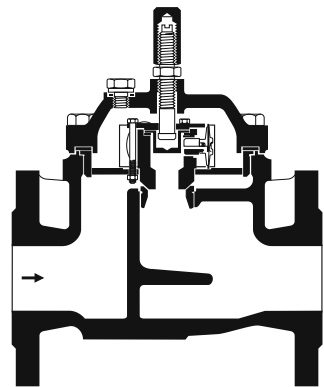

TK 23/24 DN 50

### The GESTRA TK traps at a glance

Type	Material	Max. differential pressure bar (psi)	Connections, DN	
			Flanged	
TK 23	EN-JL 1040	10 (145)	50, 65, 80, 100 mm (2", 2½", 3", 4")	
TK 24	1.0619 (GP 240 GH)	14 (200)	50, 65, 80, 100 mm (2", 2½", 3", 4")	

### The compact and low-pressure GESTRA MK traps at a glance

Type	Material	Max. differential pressure bar (psi)	Connections, DN	
			Screwed	Socket-weld
MK 35/31	1.0460	21 (305)	¾", 1½"	¾", 1½"
MK 35/32	1.0460	21 (305)	¾", 1½"	¾", 1½"
MK 36/51	A182 F304 (1.4301)	32 (465)	¼", ¾", 1½", ¾"	
MK 36/52	A182 F304 (1.4301)	32 (465)	¼", ¾", 1½", ¾"	
MK 20	EN-JM 1030 (0.8040)	4.5 (65)	Inlet: threaded male with union nut and threaded nipple. Outlet: screwed BSP ½", ¾"	

### The compact and low-pressure GESTRA MK traps up to PN 40

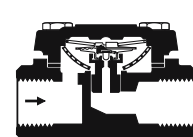

MK 35/31



MK 36/51

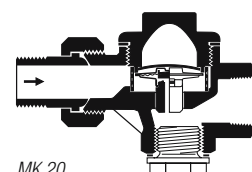

MK 20

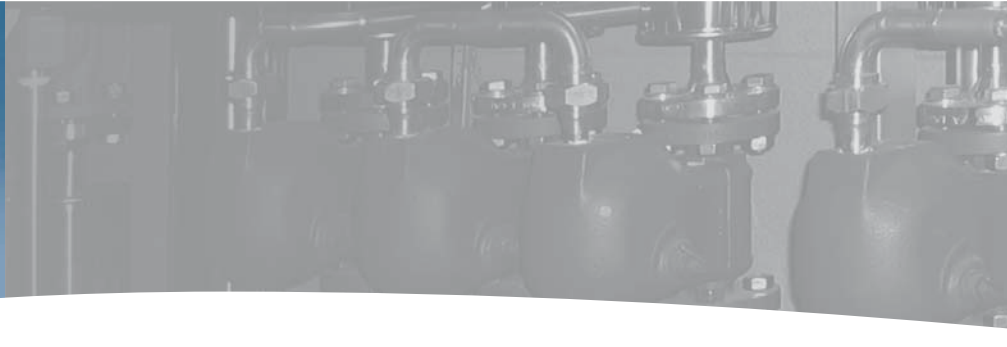

## Ball Float Traps UNA

**Pressure ratings up to PN 160**  
**For condensate discharge without banking-up even with load and pressure fluctuations**

Ball float traps are also suitable for the discharge of cold condensates, distillates and condensate derived from chemical products. They operate without any banking-up even with considerable load and pressure fluctuations and at any back pressure.

Compared with other trap types, they are the least affected by dirt. The traps are supplied with "Duplex" control (thermostatic bellows for automatic air-venting), alternatively with "Simplex" control (without bellows) and hand vent valve. The control unit is easily accessible after removing the trap cover, and can be changed as a complete unit without removing the trap from the line.

The rolling ball valve produces very little friction and can be operated with a minimum of force. This results in small, light traps but with large capacities.

### **UNA 14 PN 25, UNA 16 PN 40**

compact trap for small condensate flowrates. Design "h" for horizontal and design "v" for vertical pipework. A conversion of "h" design to "v" design or vice versa is possible by repositioning body and control unit to suit the pipework layout.

### **UNA 23 PN 16, UNA 25 PN 40, UNA 26 PN 40**

For large condensate flowrates. Design "h" for horizontal and design "v" for vertical pipework.

For particularly aggressive fluids or special hygienic requirements the UNA 26 and UNA 15 are also available made completely of stainless steel.

### **UNA 27h PN 63**

For differential pressures up to 45 bar. Installation in horizontal pipework.

### **UNA 38 PN 100, UNA 39 PN 160**

Float trap controlled by the float, only for smaller flowrates.

### **UNA 38, 80 max. orifice, PN 100 UNA 39, 140 max. orifice, PN 160**

The trap operates with pilot control (without auxiliary power). It therefore discharges large amounts of condensate at high pressures without requiring a large trap body.

### **UNA Special, PN 16–63**

Float trap without pilot control for very large condensate flowrates.

### Operation

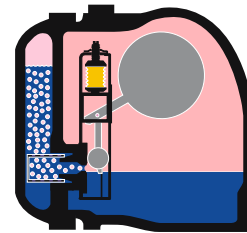

*Air-venting when system is cold (start-up condition).*

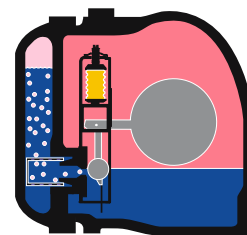

*Air-venting during operation (temperature lower than standard steam temperature).*

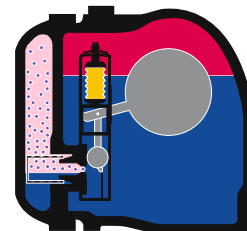

*Discharge of boiling hot condensate (temperature equals saturation temperature).*

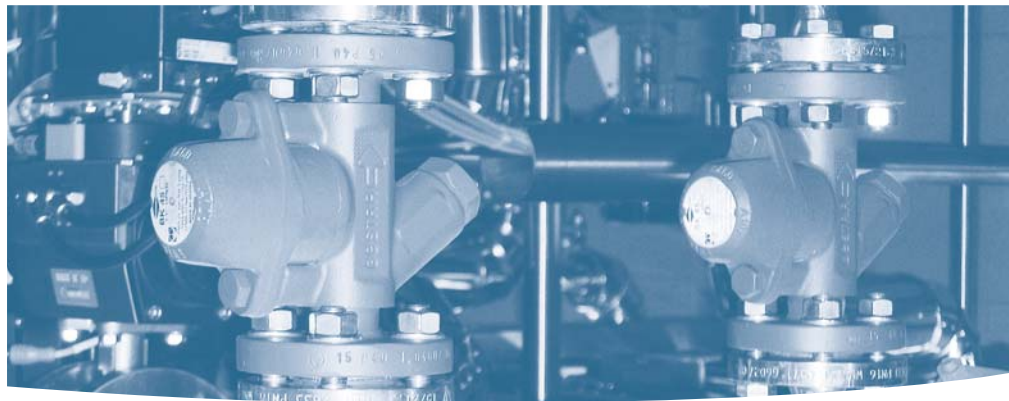
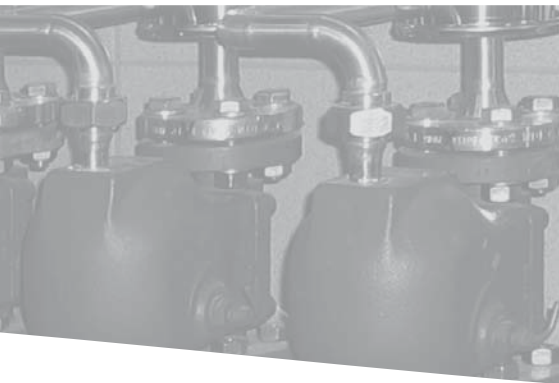

**Bolted cover** ▶

Closed or sightglass cover  
(water-level indicator)

**Upper plug** ▶

Installation of manual vent valve  
or air balance possible

**Thermostatic bellows** ▶

for automatic air-venting  
("Duplex" control). Without bellows  
("Simplex" control) for cold fluids

**Control unit** ▶

Easy maintenance after opening cover.  
Complete unit may be changed without  
removing body from pipeline

**Closing unit (orifice)** ▶

A selection of orifice sizes for high and  
low pressure applications

**Deflector** ▶

guarantees the deflection of the  
condensate stream and reduces wear  
on the trap body

**Rolling ball valve** ▶

Low friction

**Closed ball float** ▶

**Lower plug** ▶

Draining of trap or for installation of  
lifting lever

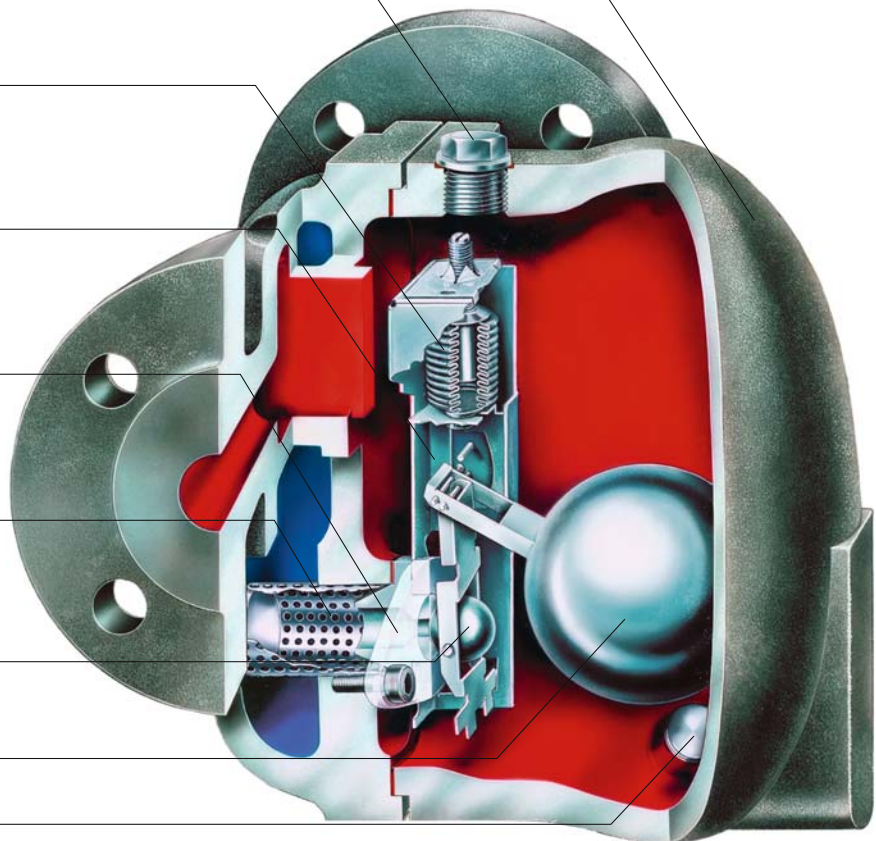



## UNA Types and Connections

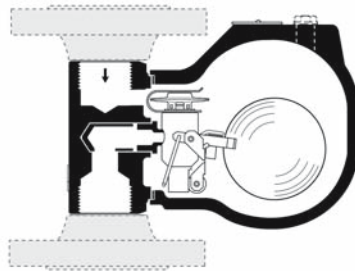

UNA 1...v

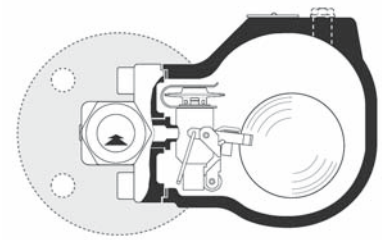

UNA 1...h

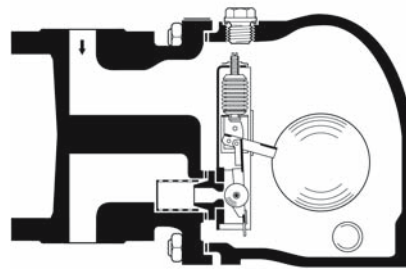

UNA 2...v

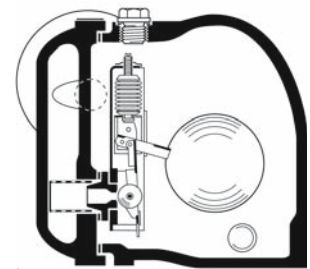

UNA 2...h

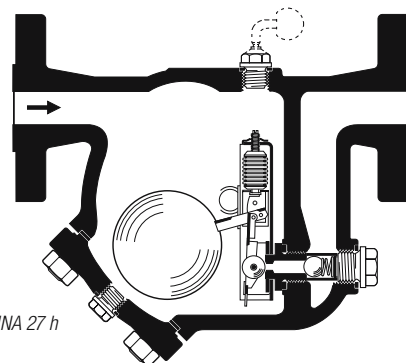

UNA 27 h

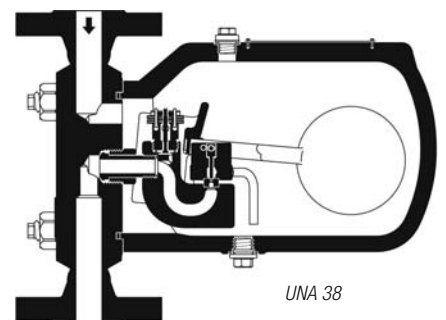

UNA 38

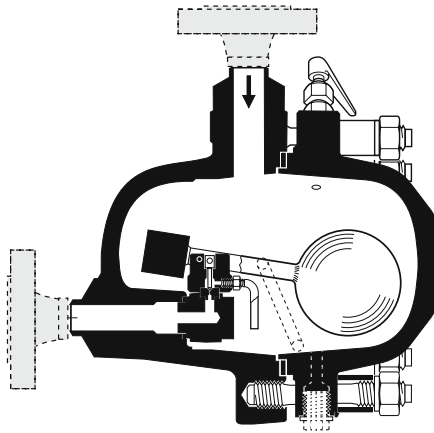
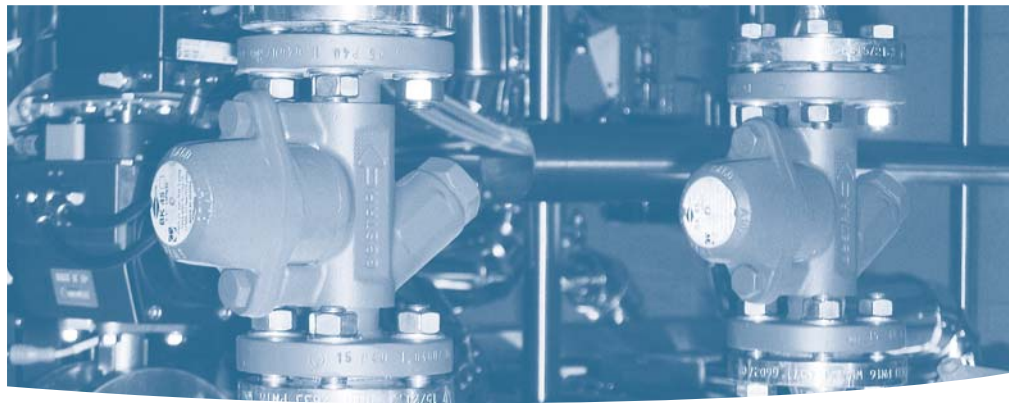
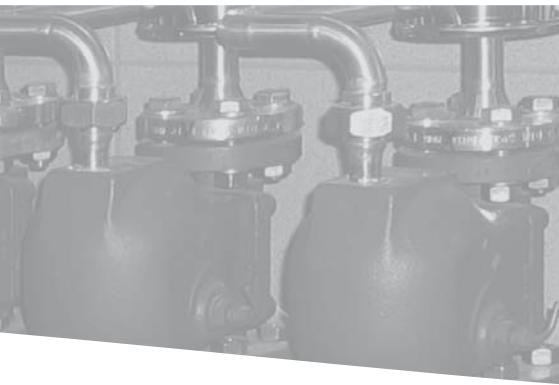

UNA 39

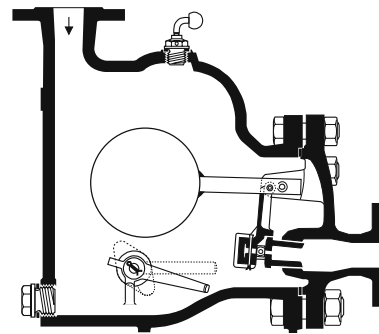

UNA Special

### UNA ball float traps at a glance

Type	Material	Max. differential pressure bar (psi)	Connections, DN			
			Flanged	Screwed	Socket-weld	Butt-weld
UNA 14h / UNA 14v	Body 1.0460 / Cover EN JS1049	13 (188)	15–25 mm (1/2"–1")	1/2"–1"		
UNA 16h / UNA 16v	Body 1.0460 / Cover 1.0619	22 (320)	15–25 mm (1/2"–1")	1/2"–1"	1/2"–1"	15–25 mm (1/2"–1")
UNA 16A h / UNA 16A v <i>Stainless steel</i>	Body 1.4404 Cover 1.4308	22 (320)	15–25 mm (1/2"–1")	1/2"–1"		
UNA 23h / UNA 23v	EN-JL1040	13 (188)	15–50 mm (1/2"–2")			
UNA 25h / UNA 25v	EN-JS1049	32 (465)	15–50 mm (1/2"–2")			
UNA 26h	Body 1.0460	32 (465)	15–50 mm (1/2"–2")	1/2"–2"	1/2"–2"	15–50 mm (1/2"–2")
UNA 26v	Cover 1.0619					
UNA 26h <i>Stainless steel</i>	1.4408	32 (465)	15–50 mm (1/2"–2")	1/2"–2"	1/2"–2"	15–50 mm (1/2"–2")
UNA 27	1.5419	45 (650)	25, 40, 50 mm (1", 1 1/2", 2")		1", 1 1/2", 2"	25, 40, 50 mm (1", 1 1/2", 2")
UNA 38h / UNA 38v	Body 1.5415 / Cover 1.7357	80 (1160)	15–50 mm (1/2"–2")		1/2"–2"	15–50 mm (1/2"–2")
UNA 39	1.7335	140 (2030)	15, 25, 50 mm (1/2", 1", 2")			15, 25, 50 mm (1/2", 1", 2")
UNA Special	EN-JL1040, 1.0619, 1.5419	16–45 (232–650)	50–100 mm (2"–4")			

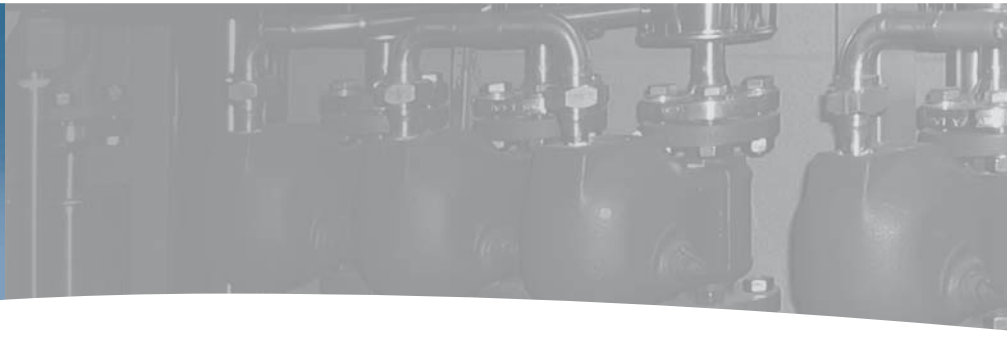

## Steam Traps ECONOline

Compact, maintenance-free steam trap of stainless steel for use with a universal swivel connector.

The main area of application is the drainage of steam lines and tracing systems.

The functional unit is mounted to the universal connector by means of two hexagon screws (supplied together with the connector). With connectors already installed in the plant, the existing screws can be used.

**ECONOline**

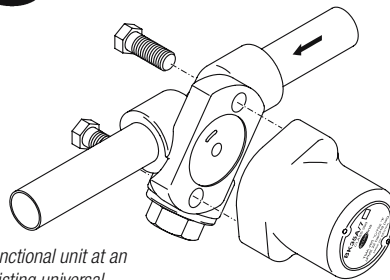

Functional unit at an existing universal connector

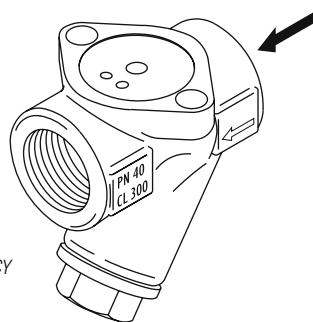

Universal connector UCY

### Your benefits at a glance

- **Mounting in any position**
- **Integrated gaskets for connector fitting**
- **Rapid installation, thanks to 2-screw mounting**
- **All functional units can be supplied with a universal connector as an option (separate component)**

The ECONOline steam trap is available with three different time-tested functional units:

#### BK 36A/7

Functional unit „thermostatic bimetallic“ with corrosion-resistant Duo stainless steel regulator unaffected by waterhammer, for automatic venting and drainage practically without any banking-up.

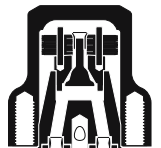

#### MK 36A/71, MK 36A/72

Functional unit „thermostatic capsule“ with corrosion-resistant membrane regulator 5N1 that is unaffected by waterhammer, for automatic venting and drainage practically without any banking-up.

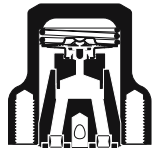

#### DK 36A/7

Functional unit „thermodynamic“ for drainage practically without any banking-up.

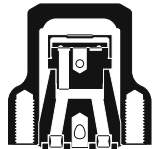

### The ECONOline steam traps at a glance

Type	Material	Max. differential pressure bar (psi)	Connections, universal connector, size (DN)		
			Screwed	Socket-weld	Butt-weld
BK 36A/7	1.4408	32 (465)	1/2"-1"	1/2"-1"	1/2"-1"
MK 36A/71, 72	1.4408	32 (465)	1/2"-1"	1/2"-1"	1/2"-1"
DK 36A/7	1.4408	32 (465)	1/2"-1"	1/2"-1"	1/2"-1"

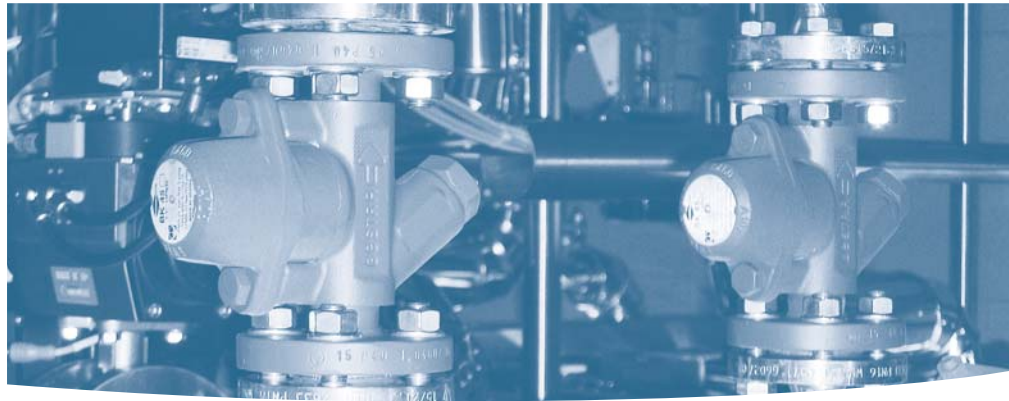
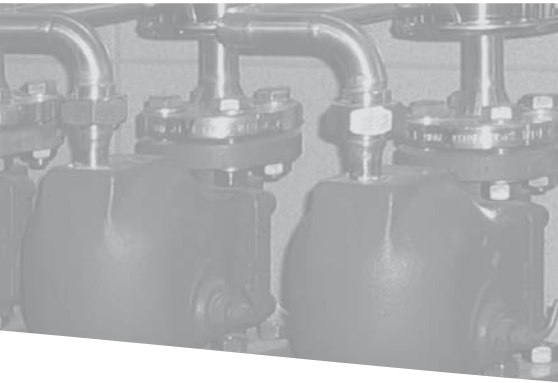

## Other Traps for Special Applications

### Condensate drain valve AK Pressure ratings up to PN 40

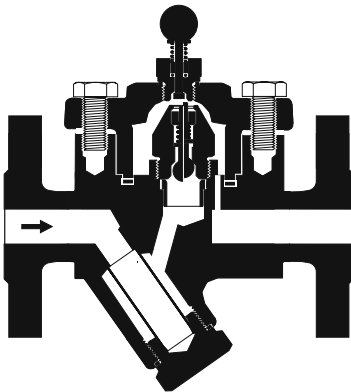

Automatic drain valve for rapid condensate discharge during the start-up of steam plants and for draining the remaining condensate at shut-down. The formation of a vacuum and possible frost damage are prevented. To avoid freezing of the AK, the drain line should be kept as short as possible and the valve be included in the thermal insulation. The valve is controlled only by the pressure. It replaces a manually operated by-pass valve.

#### Draining a steam line at start-up

At start-up of the steam line the pressure in the line is initially zero, although steam is already condensing. However, the condensate formed cannot be discharged by the steam trap into the rising condensate line, as there is not yet any differential pressure available to lift the condensate. In this case, in the past a by-pass valve mounted at the lowest point of the system had to be opened by hand, so that the condensate could drain freely. As shown in the schematic representation, the drain valve AK 45 ensures automatic condensate discharge until the pressure in the steam line has reached 0.8 bar (11.6 psi) (factory-set closing

pressure). This pressure in the steam line is sufficient for the steam trap to discharge the condensate into the condensate-return line.

At this pressure the AK 45 closes instantaneously and automatically. When the steam system is shut down, the pressure in the steam line drops slowly. As soon as the pressure has dropped below 0.8 bar, the AK 45 opens, discharges the remaining condensate and prevents the formation of vacuum.

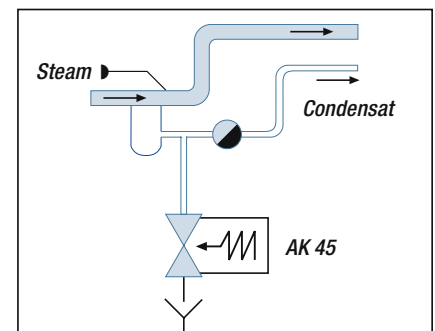

#### The AK condensate drain valve at a glance

Type	Material	Max. differential pressure bar (psi)	Connections, DN	
			Flanged	Screwed
AK 45	1.0460	0.8 (11.6)	15–25 mm (1/2"–1")	1/2"–1"

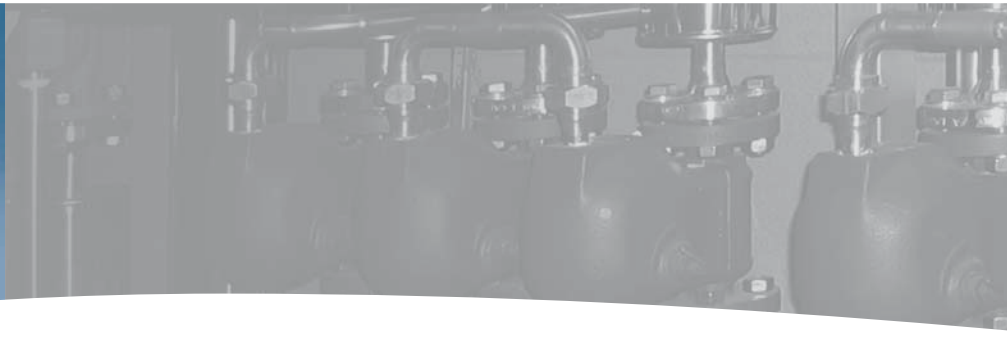

## Other Traps for Special Applications

### Steam trap UBK 46

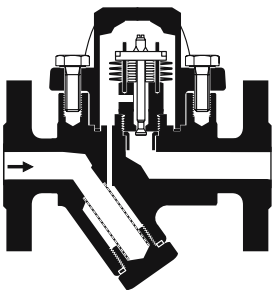

#### Pressure rating PN 40

The UBK 46 is a special version of the BK range of traps designed to save energy by holding back the condensate until it has cooled down to the adjustable discharge temperature, thus permitting the utilization of the sensible heat of the condensate

and avoiding flash steam. The Duo stainless steel thermostat is corrosion-resistant and unaffected by waterhammer. Installation in any position.

With large-surface Y-type strainer:  
Main field of application: steam heated tracing systems.

#### The UBK trap at a glance

Type	Material	Max. differential pressure bar (psi)	Connections, DN		
			Flanged	Screwed	Socket-weld
UBK 46	1.0460	32 (465)	15–25 mm (1/2"–1")	1/2"–1"	1/2"–1"

### SMK 22

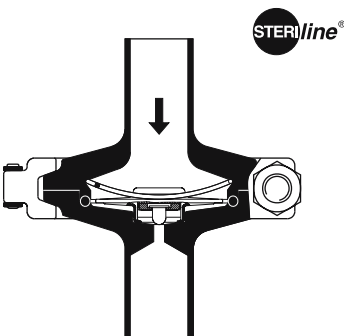

#### Pressure rating PN 10

The thermostatic steam trap features minimum stagnant area and a corrosion-resistant membrane regulator unaffected by waterhammer. Used for discharging of condensate and air venting of steam in sterile and aseptic applications.

The membrane regulator features a self-centering valve cone that can move freely, thereby ensuring steamtight shut-off unaffected by particulate mat-

ter. High sensitivity thanks to reduced dimensions of the regulator (evaporation thermostat). Automatic air-venting and discharge of condensate without any banking-up within the rated pressure/ temperature range. The opening temperature is approx. 5 K below the boiling point. All parts in contact with the fluid are made of stainless steel and the body gasket is of EPDM (O-ring) in accordance with the regulations specified by the Food and Drug Administration (FDA). The surface roughness Ra of the wetted surfaces is  $\leq 0.8 \mu\text{m}$ .

#### The SMK trap at a glance

Type	Material	Max. differential pressure bar (psi)	Connections, DN		
			Butt-weld ends	Clamp	Screwed
SMK 22	1.4435	6 (87)	3/8", 1/2", 3/4", 1"		

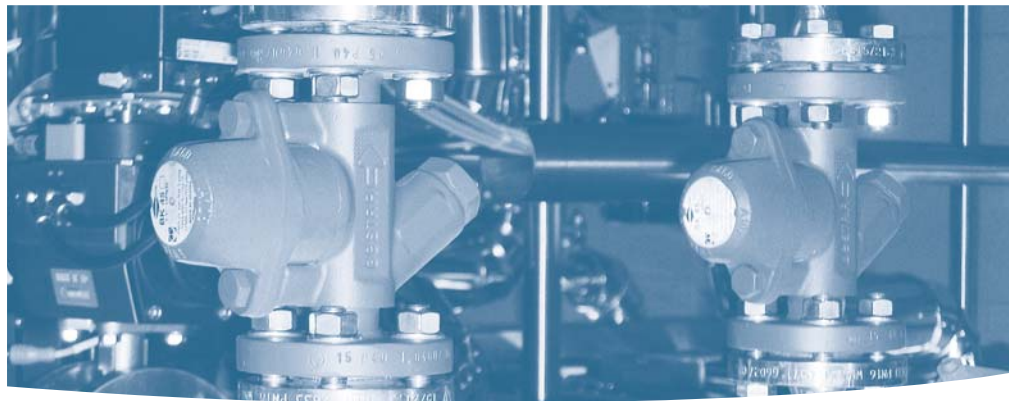
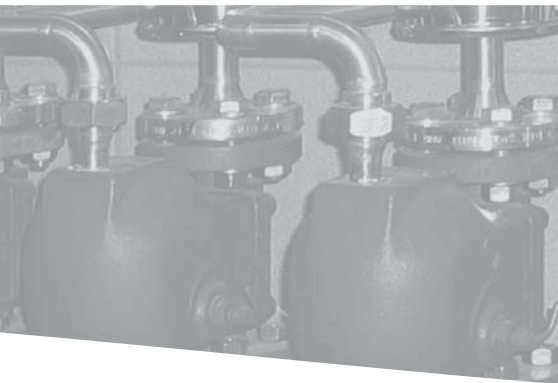

### Liquid drainer for compressed-air and gas systems PN 25

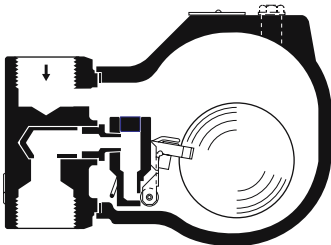

UNA 14 P

For continuous draining of gas and compressed-air systems, float traps with "Simplex" control units (i.e. without thermostatic air vent) are used.

To ensure perfect drainage, the air traps can be fitted with a balance pipe which allows air in the trap body to escape so that it cannot obstruct the flow of condensate into the trap. A balance pipe is not necessary if the trap is installed directly below the equipment to be drained and if the drain line runs vertically. In this instance the pipe leading to the trap should be of sufficient size so that any air can

escape by bubbling through the condensate. All air traps are equipped with a plug allowing a balance line to be connected, and are fitted with a float lifting lever to facilitate manual purging of the valve area. UNA traps are fitted with a perbunan rubber valve ball to provide tight closure; a stainless steel valve ball may be specified for higher temperatures and pressures.

In the case of very small condensate flowrates the tightness of the valve closure should be considered.

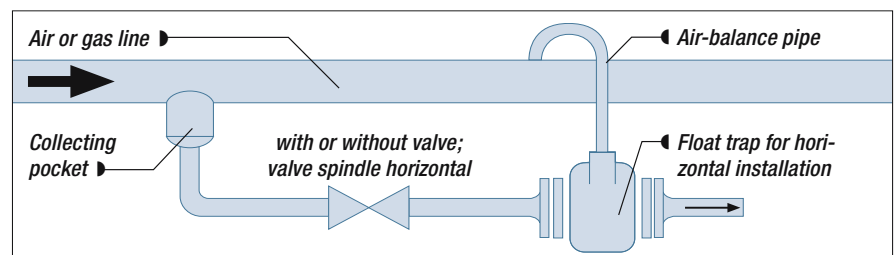

### The liquid drainer at a glance

Type	Material	Max. differential pressure bar (psi) (density 1 kg/dm <sup>3</sup> )	Connections, DN	
			Flanged	Screwed
UNA 14 P, h+v	EN-JL1040	16 (130)	15, 20, 25 mm (1/2"-1")	1/2", 3/4", 1"

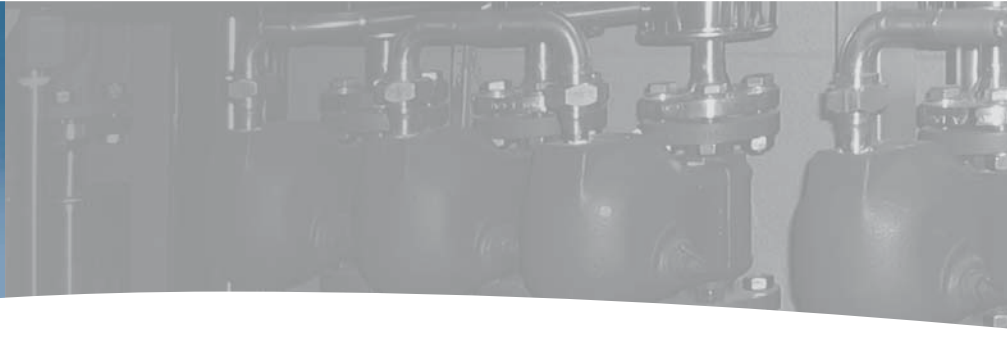

## Steam Trap Testing

### VAPOSKOP VK

#### Sightglass



#### Normal service condition

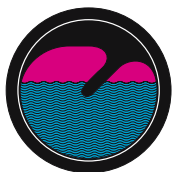

Perfect operation of steam trap and heating surface. The deflector is immersed in the water level. The formation of small bubbles or a slight turbulence are effects that can be ignored.

#### Pressure ratings up to PN 40

The GESTRA VAPOSCOPE allows visual supervision of flow conditions in pipelines. These double-sided sightglasses can be used for checking heat exchangers and condensate systems, so that disturbances are immediately recognized and loss of production avoided.

#### Operation

As the specific gravity of gaseous media (steam) is lower than that of liquids (condensate), the steam will pass over the condensate. This fact is used in the VAPOSCOPE to distinguish between steam and condensate. Condensate, steam and air are directed by a rigid deflector through the water seal.

#### Loss of live steam



Steam or air passing through the VAPOSCOPE depress the level of the condensate below the deflector. The steam which is invisible fills the space between deflector and water level. A mixture of water and steam may lead to a strong formation of bubbles together with turbulence. Possible causes for live steam loss: Contamination or failure of steam traps.

formed by the condensate in the VAPOSCOPE. Steam and gas pass over the condensate and depress the condensate level. The following conditions can be observed in the sightglass.

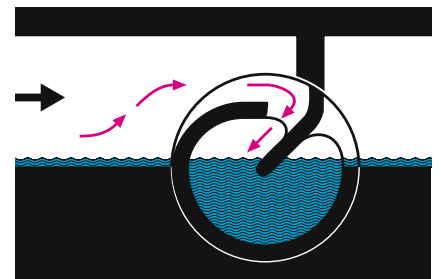

#### Banking-up of condensate

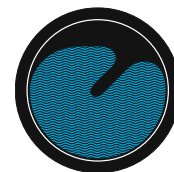

The VAPOSCOPE is completely flooded. If the VAPOSCOPE is installed immediately downstream of the heat exchanger it is to be expected that the condensate is banking up into the heat exchanger. Possible causes for banking-up of condensate: Start-up of plant, heat exchanger operates with additional undercooling, changed operating conditions (e.g. extremely high heat consumption), steam trap size not sufficient, blockage or failure of steam trap.

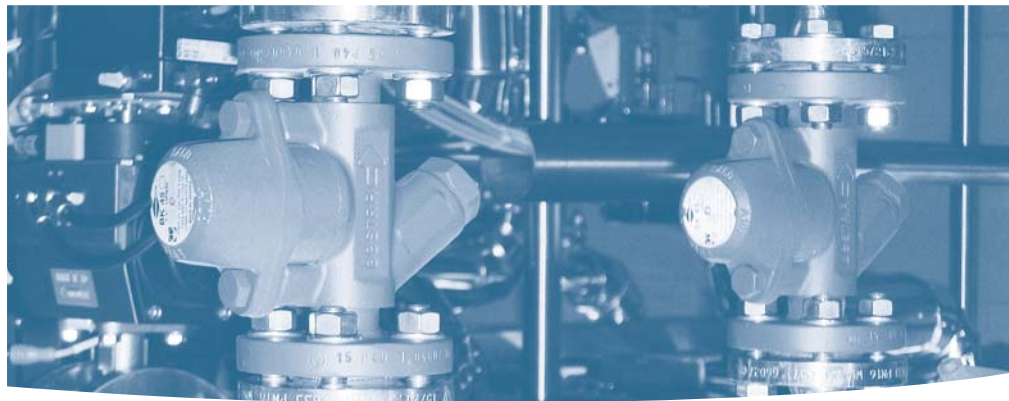
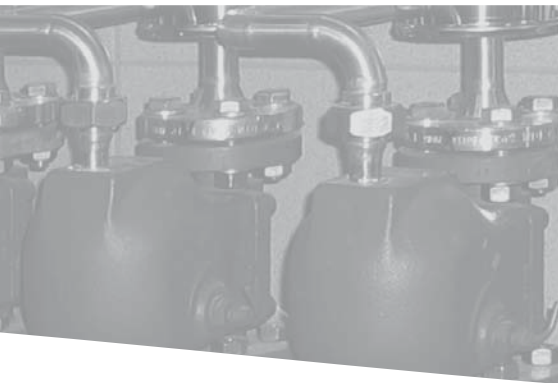

### Test set VKE

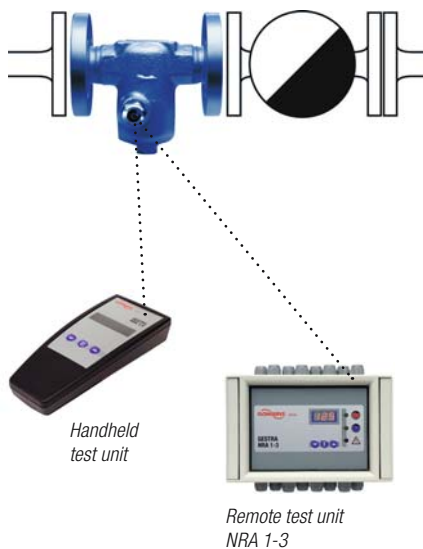

### Test set for monitoring steam traps Pressure ratings up to PN 40

The test set VKE is used for monitoring steam traps to detect the leakage of live steam and the banking-up of condensate. A separate test chamber fitted with measuring electrode is installed directly upstream of the steam trap to be monitored. The electrode is then linked either to the remote test unit or to the handheld test unit. The VKE test system with test chamber can be used for steam traps of all types and makes.

#### Operation

The electrode signals the states "condensate" or "steam" to the test unit NRA 1-3 (automatic remote monitoring) or to the handheld test unit (measuring in situ). If the steam trap operates correctly, condensate flows around the electrode. In the case of

steam losses across the trap, the condensate is displaced until the electrode is surrounded by steam. The condition is indicated accordingly. The test unit NRA 1-3 has channels for up to 16 steam traps. Each of the connected steam traps can be monitored for live steam losses and banking-up of condensate. Through various modes and inclusion of the plant temperature, the limit values are adapted automatically and faults are detected instantaneously. The maintenance interval is signalled on the front panel of the test unit, and a potential-free relay contact is used for signalling an alarm condition. The test unit is supplied in a case for wall mounting or a case for panel mounting. The VKE 26 test chamber is used for reliable monitoring of the installation for banking-up of condensate.

### VK and VKE at a glance

Type	Material	Connections, DN		
		Flanged	Screwed	Socket-weld
VK 14	EN-JL1040	15–50 mm (1/2"–2")		
VK 16	1.0460	15–50 mm (1/2"–2")	1/2"–2"	1/2"–2"
VKE 16-1 (with test chamber)	1.0619	15–50 mm (1/2"–2")	1/2"–2"	
VKE 16 A (with test chamber)	1.4571	15–50 mm (1/2"–2")		
VKE 26 (with test chamber)	1.0460		3/8"	

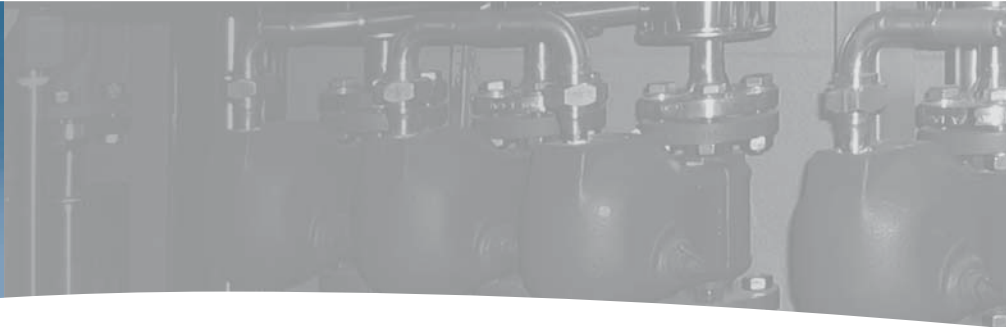

## Steam Trap Testing Units

### VAPOPHONE ultrasonic detector VKP 10



The portable ultrasonic detector is specially designed for detecting steam loss through steam traps and stop valves.

Live steam leakage is detected by sound in the ultrasonic range caused by flowing steam. The mechanical ultrasonic vibrations are detected by the probe and converted into electric signals which are amplified in the measuring instrument and indicated on a meter.

The VKP 10 must not be used in potentially explosive areas. Degree of protection IP 41.

### TRAPtest VKP 40 / VKP 40Ex

Faulty steam traps are a major source of waste in a steam distribution system. A trap that is blowing live steam is the worst offender and the decreased efficiency results in lost production.

Systematically checking steam traps for loss of live steam and consequent heat loss is therefore a matter of prime importance. This is easy to do with all types and makes of steam traps by using GESTRA's steam trap monitoring, recording and evaluation system VKP 40 / VKP 40Ex, which detects and assesses ultrasonic vibrations transmitted through the trap body by live steam flowing through the trap. The visual display of the terminal shows all signals received during the test in the form of a graph, clearly distinguishing between a trap working correctly and one passing even very small amounts of steam.

As part of the test procedure, the temperature prevailing at the steam trap is also recorded. In conjunction with specified service pressures, this makes it possible for the system to identify steam



*Hand-held terminal VKPN 40Ex for use in potentially explosive areas*

- ▶ Approval BVS 04 ATEX E 149
- ▶ CE 0158 Ex II 2G EEX ib IIC T4

traps which are obstructed (causing the condensate to bank up).

All test results obtained by the hand-held terminal can be stored, evaluated and organized on the PC. The TRAPtest VKP 40 / VKP 40Ex consists of the measuring transducer VKPS 40, the portable terminal VKPN 40 / VKPN 40Ex and the corresponding software for data management by PC.

It is well known that steam losses through trap failure, dirt in the steam trap, wrong use of traps or incorrectly installed equipment can easily waste thousands of euros a year. An optimized steam system is therefore essential and can even nowadays save up to 30% of the energy capacity. Call us in for a full mechanical and electrical service inspection of your steam and condensate system – our team of engineers are on hand to keep your installation working at peak efficiency, to maximise your maintenance budget and optimise the overall plant efficiency.

*Monitoring, recording and evaluation system TRAPtest VKP 40 (or VKP 40Ex) for checking all makes and types of steam traps for steam losses and banking-up of condensate.*



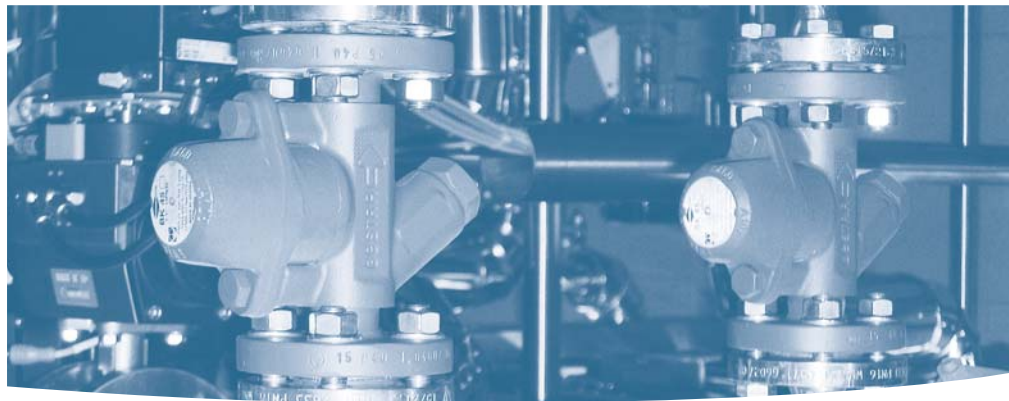
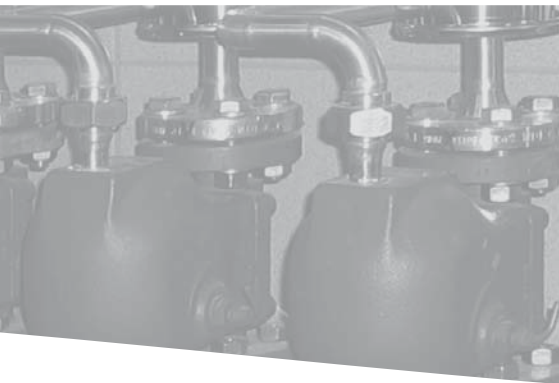

## Further Valves Suitable for Condensate Discharge

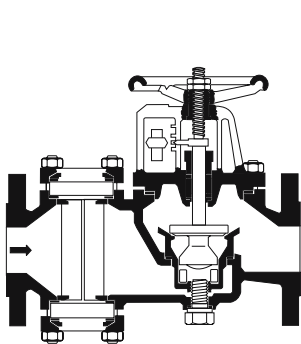

GK 11, 21

### GK Super steam trap

Steam trap with stage nozzle for discharging very large condensate flowrates. With integrated VAPOSCOPE for optimum trap adjustment.

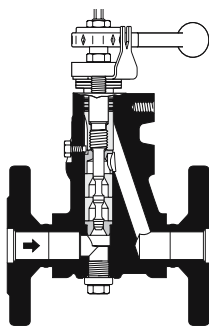

BA 46

### Regulating steam trap: Continuous blowdown valve BA Pressure ratings up to PN 320

The valve can also be used as thermodynamic steam trap with stage nozzle (without sampling valve).

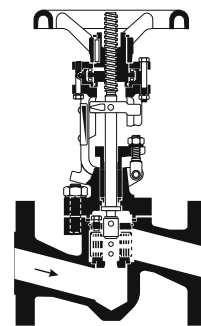

ZK 29

### Control valves ZK with radial stage nozzle Pressure ratings up to PN 630

The valve can also be used for injection-cooling, level and leak-off control, as well as for drainage duties.

## Innovations in Steam Trap Technology

### RHOMBUS*line* with new possibilities

Available on request for the RHOMBUS*line* steam traps BK 45, BK 46, MK 45 and UBK 46:

- ▶ Integrated measuring probe for monitoring the system for live steam losses and (in conjunction with a handheld test unit or test unit NRA 1-3). Without strainer.
- ▶ Integrated temperature measurement (PT-100 element with terminal box), for monitoring against banking-up. With strainer.



BK 45 with integrated measuring probe



## **GESTRA AG**

Münchener Str. 77, D-28215 Bremen  
P.O. Box 10 54 60, D-28054 Bremen  
Telephone +49 (0) 421-35 03-0  
Telefax +49 (0) 421-35 03-393  
E-mail [gestra.ag@flowserve.com](mailto:gestra.ag@flowserve.com)  
Internet [www.gestra.de](http://www.gestra.de)

