

# Steam Flow Control

VALVECO IS A DIVISION OF HALLEY & MELLOWES GROUP OF COMPANIES

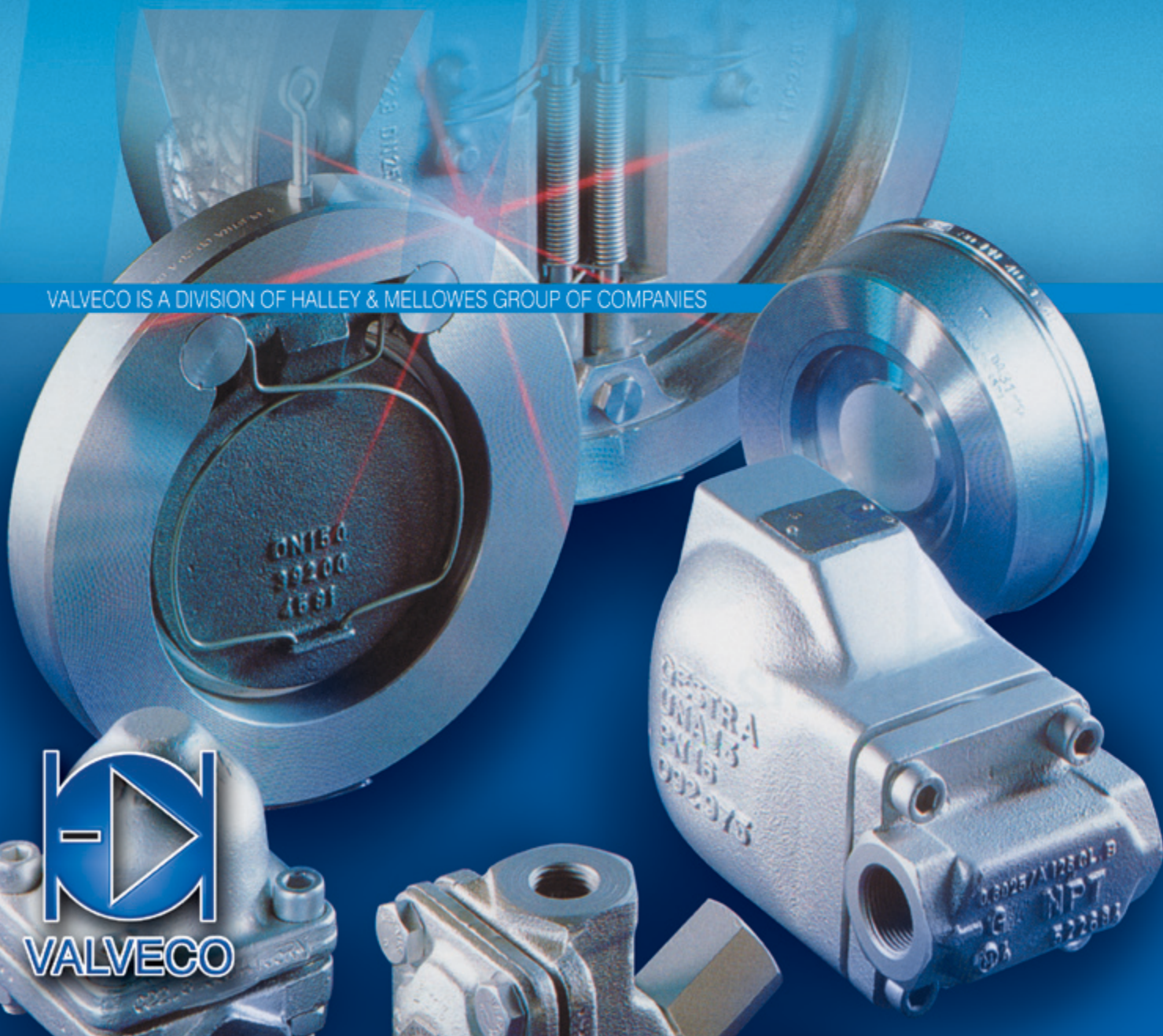

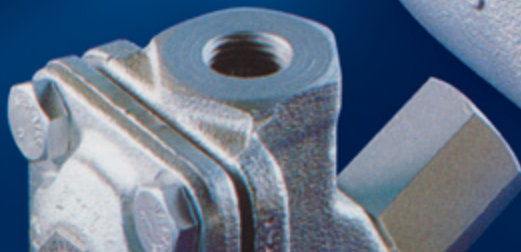
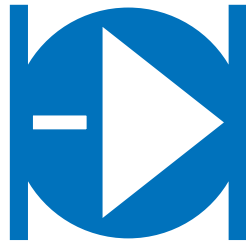

**Valveco** is a manufacturer, importer and distributor of a vast range of valves and controls. We have been supplying valves and control solutions to all industries in Australia over 30 years. The support and know-how provided by the overseas manufacturers we represent, together with our local expertise and experience enables us to provide the optimum solution to meet Customer requirements.

Valveco's service division is able to provide on-site installation, maintenance and commissioning. We also have a machine shop and workshop that is able to repair and test valves, produce special products as well as modify components.

Our prompt quotations and responses to technical queries by our qualified and trained staff and the on time delivery of quality products has won us the confidence and loyalty of Customers Australia-wide.

# To ensure perfect condensate discharge

## Gestra Steam Traps

### UNA Range

Steam traps with ball float for pressure ratings up to 170 bar (2465 psi).

Float traps are especially suited for condensate discharge without banking-up at extreme and sudden flowrate and pressure fluctuations.

**UNA 1** Adaptable to horizontal or vertical lines



**UNA 2** For particularly large condensate flowrates



**UNA 3** With pilot control, without auxiliary power

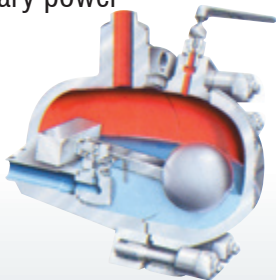

### BK Range

Thermostatic steam traps with Duo stainless steel (bimetallic) regulator for pressure ratings up to 250 bar (3625 psi).

The BK 15 traps are suited for the roughest operating conditions. Due to the Duo stainless steel regulator, these traps withstand waterhammer and freezing.

**BK 15** For applications up to 32 barg (320 psig)



**BK 212** For high pressure



**The equipment is available with all standard connections**

### MK Range

Thermostatic steam traps with membrane regulator for pressure ratings up to 32 bar (465 psi). Due to the thermostatic capsule of the membrane regulator an unexcelled regulating accuracy during condensate discharge is obtained. This trap range includes various types that are suited for small or large condensate flowrates.

**MK 35** For small condensate flowrates



**MK 25/2** For large condensate flowrates

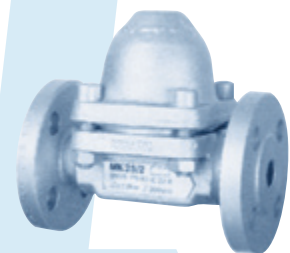

**MK 36/51** For small condensate flowrates at high pressures



# To make sure of the right direction

## Gestra Wafer Check (Non-Return) Valves

### RK 66/66a

The RK 66 non-return valve, PN 10/40, DN 15-200mm (1/2-8") with short overall length to DIN 3202, series K4 is suited for standard applications.

Optionally supplied with soft seat.

### RK66

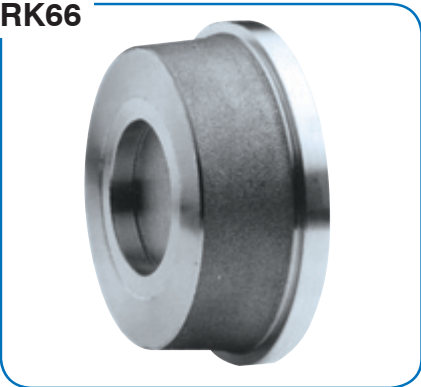

### RK 71

The RK 71 non-return valve, PN 6/10/16, DN 15-100mm (1/2-4") with short overall length to DIN 3202, series K4 is especially suited for use in heating and warm water systems.

### RK66



### RK 16/16a

The RK 16 non-return valve, PN 10/40, DN 15-100mm (1/2-4") with short overall length to DIN 3202, series K5 is suited for installation between ANSI or other flange types. The valve is also available in materials such as titanium and Hastelloy.

Optionally supplied with soft seat.

### RK16

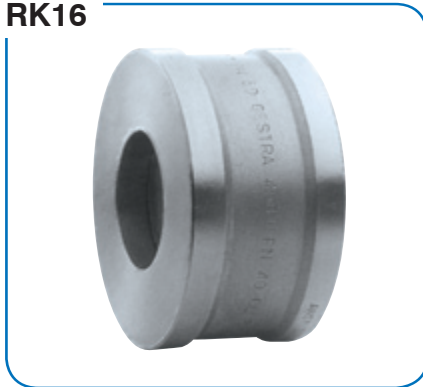

### BB

The dual-plate check valves BB, PH 6-160, DN 50-1200mm (2-48") ensure very low pressure drops and great reliability. They are also suited for gaseous media. Special designs with adjustable dampers or with anticorrosion lining are available.

### RK16



### RK 49

The RK 49 non-return valve, PN 160, DN 15-100mm (1/2-4") with short overall length to DIN 3202, series K5, is conceived as high-pressure valve for applications up to 160 barg (2320 psig).

Can be installed between flanges with different facings.

### RK49

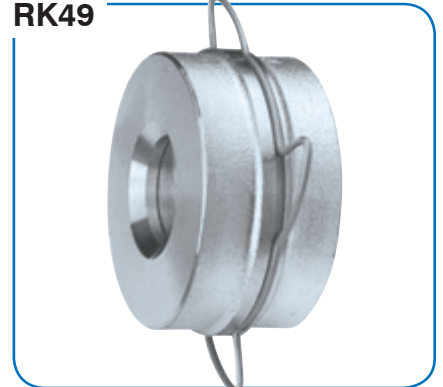

### CB 26/26a

The CB 26 swing-check valve, PN 6/40, DN 50-300mm (2-12") is a reasonably priced, yet highly effective valve. This valve range features an extremely short overall length.

### RK49



Valveco

# To detect disturbances in time

## Gestra Vaposcope Sightglasses

### VK

Allow visual supervision of flow conditions in condensate lines.

For checking heat exchangers and condensate systems. The Vaposcope can be used in vertical or horizontal lines without any modification.

### VK

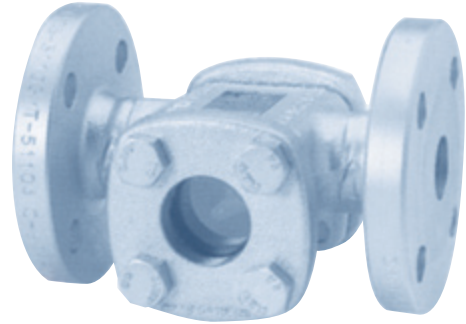

## Gestra Equipment and Vessels for Heat Recovery

Condensate recovery and return systems with horizontal or vertical tanks, also as packaged units and for hazardous areas

Flash-vessel systems

Steam driers and purifiers

Gas driers and purifiers

Mixing Coolers

## Further Products of Interest - Industrial Electronics

Level controls, low-level alarms

Conductivity (TDS) measurement and monitoring

Temperature control and limitation

Pressure control and limitation

Oil and turbidity detection

Max./min. limit switches

Steam flow measurement

Process monitoring and control

Electronic steam trap monitoring systems

**Literature on this equipment is freely available**

## Quality is our Strength

It is the task of our quality assurance system to exclude errors right from the beginning. That we are in a position to do so is proven by the recognition of our quality assurance system in accordance with ISO 9001 by Lloyd's Register Quality Assurance Ltd. The quality of our valves and vessels has been confirmed time and again by recognized type-approvals.

visit our website: [www.halmel.com.au](http://www.halmel.com.au)

**Wyong - Head Office**

10 Hereford Street, Berkeley Vale NSW 2261  
PO Box 5010 Chittaway NSW 2261  
Tel: +61 (0)2 4389 6191 Fax: +61 (0)2 4389 6198  
Email: info@hmagroup.com.au

**Sydney**

13 Sirius Road, Lane Cove NSW 2066  
Tel: +61 (0)2 9428 7300 Fax: +61 (0)2 9428 7399  
Email: artarmon@hmagroup.com.au

**Morwell**

8 Jones Road, Morwell Vic 3840  
PO Box 647 Morwell Vic 3840  
Tel: +61 (0)3 5136 8400 Fax: +61 (0)3 5136 5499  
Email: morwell@hmagroup.com.au

**Perth**

119 Dowd Street, Welshpool WA 6106  
Tel: +61 (0)8 6254 9500 Fax: +61 (0)8 6254 9599  
Email: perth@hmagroup.com.au

**Brisbane**

4th Floor, 49 Sherwood Road, Toowong QLD 4066  
PO Box 106, Toowong QLD 4066  
Tel: +61 (0)7 3359 6800 Fax: +61 (0)7 3859 6869  
Email: brisbane@hmagroup.com.au

**Mackay**

22-30 Southgate Drive, Southgate Industrial Park, Paget Qld 4740  
PO Box 6221, Mackay Mail Centre Qld 4741  
Tel: +61 (0)7 4998 6900 Fax: +61 (0)7 4998 6999  
Email: mackay@hmagroup.com.au

**Gladstone**

9 Neil Street, Gladstone Qld 4680  
PO Box 1731, Gladstone Qld 4680  
Tel: +61 (0)7 4928 3128 Fax: +61 (0)7 4928 3127  
Email: gladstone@hmagroup.com.au

**Townsville**

PO Box 347, Aitkenvale Qld 4814  
Tel: +61 (0)7 4728 6300 Fax: +61 (0)7 4728 6388  
Mobile: 0417 996 694  
Email: townsville@hmagroup.com.au

**Adelaide**

PO Box 1280, North Haven SA 5018  
Tel: +61 (0)8 8341 8067 Fax: +61 (0)2 4341 8067  
Mobile: 0437 460 032  
Email: adelaide@hmagroup.com.au

**New Zealand**

Unit 14, 9 Karewa Place, Pukete, Hamilton NZ 3200  
PO Box 10102, Te Rapa, Hamilton NZ 3200  
Tel: +64 (0)7 847 1880 Fax: +64 (0)7 847 1883  
Email: hamilton@hmagroup.com.au



visit our website: [www.hmagroup.com.au](http://www.hmagroup.com.au)